

UL 142

Steel Aboveground Tanks for  
Flammable and Combustible  
Liquids

ABDULREHMAN FAZAL || Purchased On : 1/1/19/2008 11:50:04 PM || Order Number : 081119114 || Document : 1 of 1 || ALL RIGHTS RESERVED

*UL COPYRIGHTED MATERIAL –  
NOT AUTHORIZED FOR FURTHER REPRODUCTION OR  
DISTRIBUTION WITHOUT PERMISSION FROM UL*

***UL COPYRIGHTED MATERIAL –  
NOT AUTHORIZED FOR FURTHER REPRODUCTION OR  
DISTRIBUTION WITHOUT PERMISSION FROM UL***

Underwriters Laboratories Inc. (UL)  
333 Pfingsten Road  
Northbrook, IL 60062-2096

UL Standard for Safety for Steel Aboveground Tanks for Flammable and Combustible Liquids, UL 142  
Ninth Edition, Dated December 28, 2006

Revisions: This Standard contains revisions through and including December 15, 2007.

### **Summary of Topics**

**Revisions to the ninth edition of UL 142 are being published to address numerous issues that were discussed at past STP 142 meetings. These revisions include:**

- 1. Revision to the scope for clarification**
- 2. Revisions to glossary terms**
- 3. Revisions to requirements regarding capacity and dimensions**
- 4. Revisions to requirements regarding bracings**
- 5. Revisions to requirements regarding tank bottoms and supports**
- 6. Revisions to requirements regarding manways**
- 7. Revision to requirement regarding normal and emergency venting**
- 8. Addition of a weld joint design for Figure 6.3**
- 9. Addition of a lift lug test**
- 10. Deletion of the Canadian Requirements Comparison Guide (CRG)**

Text that has been changed in any manner is marked with a vertical line in the margin. Changes in requirements are marked with a vertical line in the margin and are followed by an effective date note indicating the date of publication or the date on which the changed requirement becomes effective.

The following table lists the future effective dates with the corresponding reference.

**UL COPYRIGHTED MATERIAL –  
NOT AUTHORIZED FOR FURTHER REPRODUCTION OR  
DISTRIBUTION WITHOUT PERMISSION FROM UL**

Future Effective Dates	References
December 15, 2009	Paragraphs 8.1, 9.1, 9.1.1, 9.2, 9.4, 13.1.2, 13.3.1, 13.3.6, 13.4.1, 13.4.2, 13.4.4, 15.1.2, 15.1.3, 15.4.2, 21.3, 31.2.6, 44A.1, 44A.2, 44A.3, Tables 13.1, 13.3, 21.1, 31.1, A2, A3, and Figures 6.3, 7.1, 7.2, 9.1, 9.2, 9.3, 9.4, 13.1, 13.2,

The new and revised requirements are substantially in accordance with UL's Proposal(s) on this subject dated April 6, 2007, August 31, 2007, and September 21, 2007.

The revisions dated December 15, 2007 include a reprinted title page (page1) for this Standard.

As indicated on the title page (page 1), this UL Standard for Safety is an American National Standard. Attention is directed to the note on the title page of this Standard outlining the procedures to be followed to retain the approved text of this ANSI/UL Standard.

As indicated on the title page (page1), this UL Standard for Safety has been adopted by the Department of Defense.

The UL Foreword is no longer located within the UL Standard. For information concerning the use and application of the requirements contained in this Standard, the current version of the UL Foreword is located on ULStandardsInfoNet at: <http://ulstandardsinfo.net.ul.com/ulforeword.html>.

The master for this Standard at UL's Northbrook Office is the official document insofar as it relates to a UL service and the compliance of a product with respect to the requirements for that product and service, or if there are questions regarding the accuracy of this Standard.

UL's Standards for Safety are copyrighted by UL. Neither a printed copy of a Standard, nor the distribution diskette for a Standard-on-Diskette and the file for the Standard on the distribution diskette should be altered in any way. All of UL's Standards and all copyrights, ownerships, and rights regarding those Standards shall remain the sole and exclusive property of UL.

All rights reserved. No part of this publication may be reproduced, stored in a retrieval system, or transmitted in any form by any means, electronic, mechanical photocopying, recording, or otherwise without prior permission of UL.

Revisions of UL Standards for Safety are issued from time to time. A UL Standard for Safety is current only if it incorporates the most recently adopted revisions.

UL provides this Standard "as is" without warranty of any kind, either expressed or implied, including but not limited to, the implied warranties of merchantability or fitness for any purpose.

In no event will UL be liable for any special, incidental, consequential, indirect or similar damages, including loss of profits, lost savings, loss of data, or any other damages arising out of the use of or the inability to use this Standard, even if UL or an authorized UL representative has been advised of the possibility of such damage. In no event shall UL's liability for any damage ever exceed the price paid for this Standard, regardless of the form of the claim.

UL will attempt to answer support requests concerning electronic versions of its Standards. However, this support service is offered on a reasonable efforts basis only, and UL may not be able to resolve every support request. UL supports the electronic versions of its Standards only if they are used under the conditions and operating systems for which it is intended. UL's support policies may change from time-to-time without notification.

**UL COPYRIGHTED MATERIAL –  
NOT AUTHORIZED FOR FURTHER REPRODUCTION OR  
DISTRIBUTION WITHOUT PERMISSION FROM UL**

UL reserves the right to change the format, presentation, file types and formats, delivery methods and formats, and the like of both its printed and electronic Standards without prior notice.

Purchasers of the electronic versions of UL's Standards for Safety agree to defend, indemnify, and hold UL harmless from and against any loss, expense, liability, damage, claim, or judgement (including reasonable attorney's fees) resulting from any error or deviation introduced while purchaser is storing an electronic Standard on the purchaser's computer system.

If a single-user version electronic Standard was purchased, one copy of this Standard may be stored on the hard disk of a single personal computer, or on a single LAN file-server or the permanent storage device of a multiple-user computer in such a manner that this Standard may only be accessed by one user at a time and for which there is no possibility of multiple concurrent access.

If a multiple-user version electronic Standard was purchased, one copy of the Standard may be stored on a single LAN file-server, or on the permanent storage device of a multiple-user computer, or on an Intranet server. The number of concurrent users shall not exceed the number of users authorized.

Electronic Standards are intended for on-line use, such as for viewing the requirements of a Standard, conducting a word search, and the like. Only one copy of the Standard may be printed from each single-user version of an electronic Standard. Only one copy of the Standard may be printed for each authorized user of a multiple-user version of an electronic Standard. Because of differences in the computer/software/printer setup used by UL and those of electronic Standards purchasers, the printed copy obtained by a purchaser may not look exactly like the on-line screen view or the printed Standard.

An employee of an organization purchasing a UL Standard can make a copy of the page or pages being viewed for their own fair and/or practical internal use.

The requirements in this Standard are now in effect, except for those paragraphs, sections, tables, figures, and/or other elements of the Standard having future effective dates as indicated in the note following the affected item. The prior text for requirements that have been revised and that have a future effective date are located after the Standard, and are preceded by a "SUPERSEDED REQUIREMENTS" notice.

New product submittals made prior to a specified future effective date will be judged under all of the requirements in this Standard including those requirements with a specified future effective date, unless the applicant specifically requests that the product be judged under the current requirements. However, if the applicant elects this option, it should be noted that compliance with all the requirements in this Standard will be required as a condition of continued Listing, Recognition, and Follow-Up Services after the effective date, and understanding of this should be signified in writing.

Copyright © 2007 Underwriters Laboratories Inc.

***UL COPYRIGHTED MATERIAL –  
NOT AUTHORIZED FOR FURTHER REPRODUCTION OR  
DISTRIBUTION WITHOUT PERMISSION FROM UL***

This Standard consists of pages dated as shown in the following checklist:

Page	Date
1-8B .....	December 15, 2007
9-11 .....	December 28, 2006
12 .....	December 15, 2007
13-15 .....	December 28, 2006
16-17 .....	December 15, 2007
18-21 .....	December 28, 2006
22 .....	December 15, 2007
23-24 .....	December 28, 2006
25-26 .....	December 15, 2007
27 .....	December 28, 2006
28-31 .....	December 15, 2007
32 .....	December 28, 2006
33-43 .....	December 15, 2007
44-48 .....	December 28, 2006
49 .....	December 15, 2007
50-55 .....	December 28, 2006
56-56B .....	December 15, 2007
57-60 .....	December 28, 2006
A1 .....	December 28, 2006
A2-A4 .....	December 15, 2007
SR1-SR16 .....	December 15, 2007

DECEMBER 28, 2006  
(Title Page Reprinted: December 15, 2007)



ANSI/UL 142-2007

1

## UL 142

### Standard for Steel Aboveground Tanks for Flammable and Combustible Liquids

The first edition was titled Horizontal and Vertical Aboveground Storage Tanks for Hazardous Liquids. The second edition was titled Aboveground Storage Tanks for Hazardous Liquids.

First Edition – December, 1922  
Second Edition – October, 1953  
Third Edition – May, 1968  
Fourth Edition – December, 1972  
Fifth Edition – December, 1981  
Sixth Edition – September, 1987  
Seventh Edition – April, 1993  
Eighth Edition – July, 2002

#### Ninth Edition

**December 28, 2006**

The most recent designation of ANSI/UL 142 as an American National Standard (ANSI) occurred on December 12, 2007. The ANSI approval for this standard does not include the cover page, transmittal pages, or the title page.

This ANSI/UL Standard for Safety, which consists of the Ninth edition with revisions through December 15, 2007, is under continuous maintenance, whereby each revision is ANSI approved upon publication.

An effective date included as a note immediately following certain requirements is one established by Underwriters Laboratories Inc. and is not part of the ANSI approved standard.

The Department of Defense (DoD) has adopted UL 142 on August 11, 1989. The publication of revised pages or a new edition of this Standard will not invalidate the DoD adoption.

Revisions of this Standard will be made by issuing revised or additional pages bearing their date of issue. A UL Standard is current only if it incorporates the most recently adopted revisions, all of which are itemized on the transmittal notice that accompanies the latest set of revised requirements. Comments or proposals for revisions on any part of the Standard may be submitted to UL at any time. Proposals should be submitted via a Proposal Request in UL's On-Line Collaborative Standards Development System (CSDS) at <http://csds.ul.com>.

**COPYRIGHT © 1981, 2007 UNDERWRITERS LABORATORIES INC.**

**NOT AUTHORIZED FOR FURTHER REPRODUCTION OR  
DISTRIBUTION WITHOUT PERMISSION FROM UL**

ABDULREHMAN FAZAL || Purchased On : 1/1/19/2008 11:50:04 PM || Order Number : 081119114 || Document : 1 of 1 || ALL RIGHTS RESERVED

No Text on This Page

ABDULREHMAN FAZAL || Purchased On : 1/1/19/2008 11:50:04 PM || Order Number : 081119114 || Document : 1 of 1 || ALL RIGHTS RESERVED

***UL COPYRIGHTED MATERIAL –  
NOT AUTHORIZED FOR FURTHER REPRODUCTION OR  
DISTRIBUTION WITHOUT PERMISSION FROM UL***



**CONTENTS**

**INTRODUCTION**

1 Scope .....6  
 2 General .....7  
     2.1 Units of Measurement .....7  
     2.2 Undated references .....7  
 3 Glossary .....7

**CONSTRUCTION – ALL TANKS**

4 Capacities and Dimensions .....8A  
 5 Materials .....8A  
 6 Joints .....9  
 7 Tank Connections .....15  
 8 Venting .....22  
 9 Manholes .....25  
 10 Fill, Drain, and Gauge Openings .....33  
 11 Painting .....33

**PART I – PRIMARY CONTAINMENT TANKS**

**HORIZONTAL CYLINDRICAL CONSTRUCTIONS**

12 General .....33  
 13 Construction .....33  
     13.1 Capacities and dimensions .....33  
     13.2 Steel thickness .....34  
     13.3 Heads and head joints .....34  
     13.4 Compartment tank construction .....37

**VERTICAL CYLINDRICAL CONSTRUCTIONS**

14 General .....39  
 15 Construction .....40  
     15.1 Capacities and dimensions .....40  
     15.2 Steel thickness .....40  
     15.3 Tank top (roof) .....40  
     15.4 Tank bottom (floor) .....41

**RECTANGULAR CONSTRUCTIONS**

16 General .....41  
 17 Construction .....41  
     17.1 General .....41  
     17.2 Steel thickness .....41  
 18 Performance .....41  
     18.1 Hydrostatic strength test .....41  
     18.2 Top load test .....42

**UL COPYRIGHTED MATERIAL –  
 NOT AUTHORIZED FOR FURTHER REPRODUCTION OR  
 DISTRIBUTION WITHOUT PERMISSION FROM UL**

ABDULREHMAN FAZAL || Purchased On : 1/1/19/2008 11:50:04 PM || Order Number : 0811 19114 || Document : 1 of 1 || ALL RIGHTS RESERVED

**PART II – SECONDARY CONTAINMENT TANKS**

**ALL SECONDARY CONTAINMENT TANK CONSTRUCTIONS**

19 General ..... 42

**HORIZONTAL CYLINDRICAL CONSTRUCTIONS**

20 General ..... 42  
21 Construction ..... 42

**VERTICAL CYLINDRICAL CONSTRUCTIONS**

22 General ..... 42B  
23 Construction ..... 44  
    23.1 General ..... 44  
    23.2 Tank bottom (floor) ..... 44

**RECTANGULAR CONSTRUCTIONS**

24 General ..... 45  
25 Construction ..... 45  
26 Performance Test ..... 45  
    26.1 Hydrostatic strength test ..... 45  
    26.2 Top load test ..... 45

**PART III – DIKED TANKS**

27 General ..... 45  
    27.1 Details ..... 45  
    27.2 Dike capacity ..... 46  
28 Construction ..... 46  
    28.1 All diked tanks ..... 46  
    28.2 Open top dike constructions ..... 46  
    28.3 Closed top dike constructions ..... 46  
29 Performance Tests ..... 47  
    29.1 General ..... 47  
    29.2 Buoyancy test ..... 47  
    29.3 Hydrostatic load test ..... 47

**PART IV – TANK SUPPORTS**

30 General ..... 47  
    30.1 All constructions ..... 47  
    30.2 Horizontal cylindrical tank constructions ..... 47  
    30.3 Vertical cylindrical tank constructions ..... 48  
    30.4 Rectangular tank constructions ..... 48  
31 Construction ..... 48  
    31.1 General ..... 48  
    31.2 Saddles ..... 48  
32 Performance Tests ..... 50

**UL COPYRIGHTED MATERIAL –  
NOT AUTHORIZED FOR FURTHER REPRODUCTION OR  
DISTRIBUTION WITHOUT PERMISSION FROM UL**

ABDULREHMAN FAZAL || Purchased On : 1/1/19/2008 11:50:04 PM || Order Number : 0811 19114 || Document : 1 of 1 || ALL RIGHTS RESERVED

**PART V – TANK ACCESSORIES, COMPONENTS, AND SPECIAL CONSTRUCTIONS**

33 General .....50  
     33.1 All types .....50  
     33.2 Materials .....50  
 34 Ladders .....50  
 35 Stairs .....51  
 36 Runways .....51  
 37 Heating Coils and Hot Wells .....52  
 38 Sumps .....52

**PERFORMANCE TEST METHODS**

39 Tank Leakage Test .....52  
     39.1 Caution .....52  
     39.2 Primary containment tanks .....52  
     39.3 Secondary containment tanks .....53  
 40 Hydrostatic Strength Test .....53  
     40.1 General .....53  
     40.2 Test apparatus .....53  
     40.3 Primary containment tanks .....54  
     40.4 Secondary containment tanks .....54  
 41 Top Load Test .....56  
 42 Buoyancy Test .....56  
 43 Hydrostatic Load Test .....56  
 44 Tank Support Load Test .....56  
 44A Lift Lug Test .....56A

**MANUFACTURING AND PRODUCTION TESTS**

45 Primary and Secondary Containment Tanks .....57  
 46 Diked Tanks .....57

**MARKINGS**

47 General .....57  
 48 Marking Elements .....57  
     48.1 All tanks .....57  
     48.2 Compartment tanks .....58  
     48.3 Secondary containment tanks .....58  
     48.4 Diked tanks .....58  
     48.5 Rectangular tanks .....59  
 49 Marking Method and Location .....59

**APPENDIX A Capacity and Wetted Area Tables**

ABDULREHMAN FAZAL || Purchased On : 1/1/19/2008 11:50:04 PM || Order Number : 081119114 || Document : 1 of 1 || ALL RIGHTS RESERVED

*UL COPYRIGHTED MATERIAL –  
 NOT AUTHORIZED FOR FURTHER REPRODUCTION OR  
 DISTRIBUTION WITHOUT PERMISSION FROM UL*

## INTRODUCTION

### 1 Scope

1.1 These requirements cover steel primary, secondary and diked type atmospheric storage tanks intended for noncorrosive, stable flammable and combustible liquids that have a specific gravity not exceeding 1.0 in aboveground applications.

1.1 revised December 15, 2007

1.1.1 Each tank type may be fabricated in a combination of various shapes (cylindrical, rectangular or obround) and orientations (horizontal, vertical) with or without multiple compartments, as covered in this Standard.

1.1.1 added December 15, 2007

1.2 These tanks are intended for installation and use in accordance with the Flammable and Combustible Liquids Code, NFPA 30; the Standard for Installation of Oil-Burning Equipment, NFPA 31; the Motor Fuel Dispensing Facilities and Repair Garages, NFPA 30A; the Standard for the Installation and Use of Stationary Combustion Engines and Gas Turbines, NFPA 37; the Uniform Fire Code, NFPA 1; and the International Fire Code published by the International Code Council.

1.2 revised December 15, 2007

1.3 The tanks covered by these requirements are fabricated, inspected and tested for leakage before shipment from the factory as completely assembled vessels.

1.3 revised December 15, 2007

1.4 These requirements do not apply to tanks covered by the Specification for Field-Welded Tanks for Storage of Production Liquids, API 12D; and the Specification for Shop-Welded Tanks for Storage of Production Liquids, API 12F.

1.4 revised December 15, 2007

1.5 *Deleted December 15, 2007*

1.6 These requirements do not cover special evaluations for resistance to hurricanes, tornadoes, earthquakes, floods, or other natural disasters; or resistance to vehicle impact.

1.6 revised December 15, 2007

1.7 These requirements do not cover portable tanks intended for transporting flammable or combustible liquids (such as shipping containers), or mobile use applications (such as mounted on a trailer). These types of products are covered by separate UN, DOT, or equipment product standards.

1.7 revised December 15, 2007

## 2 General

### 2.1 Units of Measurement

2.1.1 Values stated without parentheses are the requirement. Values in parentheses are explanatory or approximate information.

### 2.2 Undated references

2.2.1 Any undated reference to a code or standard appearing in the requirements of this standard shall be interpreted as referring to the latest edition of that code or standard.

## 3 Glossary

3.1 For the purpose of this standard the following definitions apply.

3.1.1 ABOVEGROUND TANK (ABOVEGROUND STORAGE TANK or AST) – A storage tank that is intended for installation above grade, at grade or below grade without backfill.

3.1.1 added December 15, 2007

3.2 ATMOSPHERIC TANK – A storage tank that has been designed to operate at pressures from – 0.5 psig to 1.0 psig (– 3.4 kPa to 6.9 kPa) measured at the top of the tank.

3.2 revised December 15, 2007

3.3 *Deleted December 15, 2007*

3.3.1 DIKE – A single wall construction forming a bottom and sides with open or closed top intended to provide secondary containment of aboveground tank(s) but not intended to be pressurized for leak testing. Dike types include combinations of rectangular or cylindrical shapes or horizontal or vertical orientations. Open top dike constructions do not have covers to prevent precipitation or debris from entering the dike area. Closed top dike constructions have covers to resist precipitation or debris from entering the dike area.

3.3.1 added December 15, 2007

3.4 DIKED TANK – A primary or secondary containment tank within a steel open or closed dike intended to provide at least 110 percent containment capacity of the primary tank(s) and spill containment.

3.4 revised December 15, 2007

3.5 *Deleted December 15, 2007*

3.6 EMERGENCY VENT – A storage tank opening or device that automatically relieves excessive internal pressure due to an external fire exposure or blockage of the normal vent.

3.6 revised December 15, 2007

3.6.1 INTERSTITIAL SPACE (ANNULAR SPACE or INTERSTICE) – A space between the walls of a multiple wall tank that is capable of communicating fluid from a leak in an adjacent wall to a collection point for monitoring.

3.6.1 added December 15, 2007

**UL COPYRIGHTED MATERIAL –  
NOT AUTHORIZED FOR FURTHER REPRODUCTION OR  
DISTRIBUTION WITHOUT PERMISSION FROM UL**

3.7 NORMAL VENT – A storage tank opening or device that automatically relieves internal pressure or vacuum during normal storage (atmospheric pressure equalization) and during normal operations (fill or withdraw). Normal vents are designed so as not to exceed 1.0 psig (6.9 kPa) pressure and minus 0.5 psig (minus 3.4 kPa) in the tank.

3.7 revised December 15, 2007

3.8 Deleted December 15, 2007

3.8.1 PERFORMANCE TESTS – A complete evaluation conducted on a limited quantity of representative tanks. These tests are intended to verify compliance with all applicable performance requirements in a standard.

3.8.1 added December 15, 2007

3.8.2 PRIMARY CONTAINMENT – The ability of a tank design and construction to contain a liquid while in normal use.

3.8.2 added December 15, 2007

3.9 PRIMARY CONTAINMENT TANK – The wall of a tank construction that provides primary containment.

3.9 revised December 15, 2007

3.9.1 PRODUCTION TESTS – A limited evaluation conducted on each tank prior to shipping. These tests are intended to verify compliance with production requirements in a standard, such as leakage.

3.9.1 added December 15, 2007

3.9.2 SECONDARY CONTAINMENT – The ability of a tank design or construction to contain a liquid only in abnormal use (from primary containment leakage or rupture).

3.9.2 added December 15, 2007

3.10 SECONDARY CONTAINMENT ABOVEGROUND TANK FOR FLAMMABLE LIQUIDS – A primary containment aboveground tank contained within a steel secondary containment shell forming an interstitial (annular) space, which is capable of being monitored for leakage into the space from either the interior or exterior walls. Secondary containment aboveground tank types include: horizontal cylindrical, vertical cylindrical, and rectangular.

3.10 revised December 15, 2007

3.11 STORAGE TANK (TANK) – A vessel having a liquid capacity that exceeds 60 gal (230 L), is intended for stationary installation, and is not used for processing.

3.11 revised December 15, 2007

3.12 TANK ACCESSORY – Optional devices or components of an aboveground tank intended to provide a specific function, such as walking or climbing access, load bearing support, spill containment, venting or heating.

3.12 added December 15, 2007

**UL COPYRIGHTED MATERIAL –  
NOT AUTHORIZED FOR FURTHER REPRODUCTION OR  
DISTRIBUTION WITHOUT PERMISSION FROM UL**

## CONSTRUCTION – ALL TANKS

### 4 Capacities and Dimensions

4.1 Capacities, dimensions, and construction details shall comply with the applicable requirements of this standard.

4.2 Capacities per foot of length or height of cylindrical shells are given in Table A1 of Appendix A for convenience in checking capacities of tanks of various diameters.

4.3 The total (actual) capacity of a tank shall not be:

- a) Less than the rated nominal capacity and
- b) More than 105 percent of the rated nominal capacity.

4.3 effective June 28, 2007

### 5 Materials

5.1 A tank shall be constructed of commercial or structural grade carbon steel per 5.2 or Type 304 or 316 stainless steel per 5.3. Only new material shall be used.

5.1 effective June 28, 2007

5.2 Carbon steel shall be in accordance with (a), (b), or both:

- a) Comply with the Specification for Carbon Structural Steel, ASTM A36M; or Specification for Steel, Sheet and Strip, Hot Rolled, Carbon, Structural, High-Strength Low-Alloy and High-Strength Low-Alloy with Improved Formability, ASTM A1011/A1011M; or Specification for Steel, Sheet and Strip, Heavy-Thickness Coils, Carbon, Hot-Rolled, ASTM A635/A635M.
- b) Have a carbon content of 0.3 percent or less, or a carbon equivalency (CE) of 0.53 percent or less as determined by the formula below, and mechanical strength and welding characteristics at least equivalent to one of the steels specified in 5.2(a).

$$CE = C + (Mn + Si)/6 + (Cr + Mo + V)/5 + (Ni + Cu)/15$$

*in which:*

*(C = Carbon, Mn = Manganese, Si = Silicone, Cr = Chromium, Mo = Molybdenum, V = Vanadium, Ni = Nickel and Cu = Copper)*

5.2 effective June 28, 2007

5.3 Stainless steel shall comply with the Specification for Stainless and Heat-Resisting Chromium-Nickel Steel Plate, Sheet, and Strip, ASTM A167; or Specification for Heat-Resisting Chromium and Chromium-Nickel Stainless Steel Plate, Sheet, and Strip for Pressure Vessels, ASTM A240/A240M.

**UL COPYRIGHTED MATERIAL –  
NOT AUTHORIZED FOR FURTHER REPRODUCTION OR  
DISTRIBUTION WITHOUT PERMISSION FROM UL**

No Text on This Page

ABDULREHMAN FAZAL || Purchased On : 1/1/19/2008 11:50:04 PM || Order Number : 081119114 || Document : 1 of 1 || ALL RIGHTS RESERVED

***UL COPYRIGHTED MATERIAL –  
NOT AUTHORIZED FOR FURTHER REPRODUCTION OR  
DISTRIBUTION WITHOUT PERMISSION FROM UL***



5.4 The thickness of steel is to be determined by five micrometer readings equally spaced along the edge of the full piece as rolled. Thickness is to be determined on the plate or sheet not less than 3/8 inch (9.5 mm) from a cut edge and not less than 3/4 inch (19.1 mm) from a mill edge.

## 6 Joints

6.1 Joint types for specific tank geometries shall be selected from Table 6.1 and shall comply with the constructions referenced in the appropriate Figures.

**Table 6.1**  
**Joint types**

Tank type	Joint types				
	Shells Figure 6.1	Heads Figure 6.2	Bottom Figure 6.3	Roof Figure 6.4	Corner Figure 6.5
Horizontal cylindrical (primary and secondary)	All <sup>a</sup>	All	–	–	–
Vertical cylindrical (primary and secondary)	All <sup>a</sup>	–	All	All	–
Rectangular (primary and secondary)	All	–	–	–	All
Diked (open and closed top)	All	–	–	–	All

<sup>a</sup> Shell joint #6 shall not be used on tanks with a diameter greater than 65 inches (1.65 m) unless it is used on the shell of the secondary containment tank where the secondary containment shell is in direct contact with the primary tank.

**Figure 6.1**  
**Shell joints**



NO. 1

Double-welded U, V, bevel, or square groove butt joint.



NO. 2

Full penetration and complete fusion.



NO. 3

Double-welded full fillet lap joint, or single-welded full fillet lap joint on outside with 1-inch (25.4-mm) intermittent weld spaced not over 12 inches (0.3 m) on inside; minimum overlap, "A" – 1/2 inch (12.7 mm) for tank diameters 48 inches (1.2 m) or less, 3/4 inch (19.1 mm) for tank diameters over 48 inches (1.2 m).

S2054C

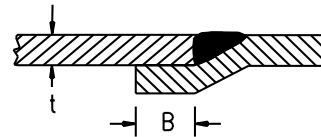

NO. 4

Groove weld equivalent in thickness to "t"; full penetration and complete fusion; minimum overlap, "B" – 1/2 inch (12.7 mm).

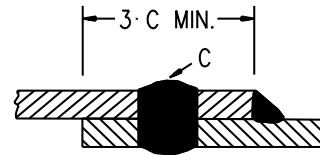

NO. 5

Full fillet weld on outside; "C" is 1/2 inch (12.7 mm) minimum diameter lock weld spaced not over 12 inches.

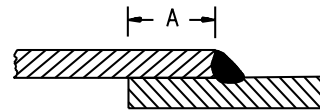

NO. 6

Single-welded full fillet lap joint; minimum overlap, "A" – 1/2 inch (12.7 mm) for tank diameters 48 inches (1.2 m) or less, 3/4 inch (19.1 mm) for tank diameters over 48 inches (1.2 m). This joint shall not be used on tanks with a diameter greater than 65 inches (1.65 m) unless it is used on the shell of the secondary containment tank where the secondary containment shell is in direct contact with the primary tank.

**Figure 6.2**  
**Head joints for horizontal cylindrical tanks**



Double-welded U, V, bevel or square groove butt joint; full penetration and complete fusion.

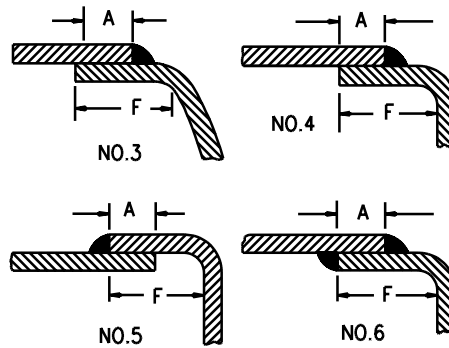

Single-welded full fillet lap joint, single-welded full fillet lap joint on outside with 1-inch (25.4 mm) intermittent weld spaced not over 12 inches (0.3 m) on inside, or double-welded full fillet lap joint; minimum overlap, "A" - 1/2 inch (12.7 mm); "F" is five times head thickness or greater, but not less than 1/2 inch (12.7 mm).

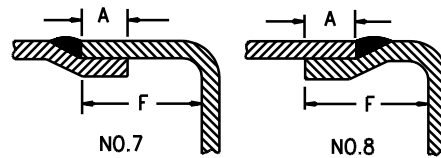

Groove weld equivalent in thickness to that of head or shell; minimum overlap, "A" - 1/2 inch (12.7 mm); "F" is five times head thickness or greater, but not less than 1/2 inch (12.7 mm).

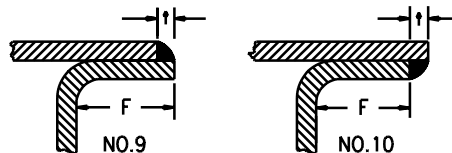

Full fillet weld; "t" - not less than thickness of shell; "F" is five times head thickness or greater, but not less than 1/2 inch (12.7 mm).

S2055B

**UL COPYRIGHTED MATERIAL –  
 NOT AUTHORIZED FOR FURTHER REPRODUCTION OR  
 DISTRIBUTION WITHOUT PERMISSION FROM UL**

**Figure 6.3**  
**Bottom joints for vertical cylindrical tanks**

Revised Figure 6.3 effective December 15, 2009

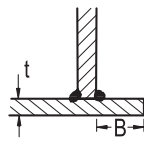

NO. 1

Double-welded full fillet joint; minimum overlap, "B" - 1/2 inch (12.7 mm) or 1-1/2 t, whichever is greater.

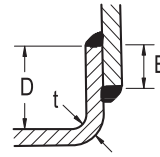

NO. 2

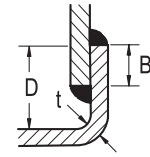

NO. 3

Double-welded full fillet lap joint; minimum overlap, "B" - 1/2 inch (12.7 mm) or 1-1/2t, whichever is greater; "D" is 5t or greater, but not less than 1 inch (25.4 mm).

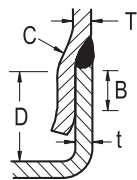

NO. 4

Groove weld at least equivalent in thickness to that of thinner member joined; minimum overlap, "B" - 1/2 inch (12.7 mm) or 1-1/2 t, whichever is greater; depth of offset, "C" - equals T; "D" is 5t or greater, but not less than 1/2 inch (12.7 mm).



NO. 5

Double-welded U, V, bevel, or square groove butt joint; full penetration and complete fusion.

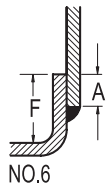

NO. 6

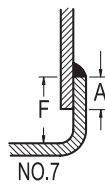

NO. 7

Single-welded full fillet lap joint, single-welded full fillet lap joint on outside with 1-inch (25.4 mm) intermittent weld spaced not over 12 inches (0.3 m) on inside; minimum overlap, "A" - 1/2 inch (12.7 mm); "F" is five times head thickness or greater, but not less than 1/2 inch (12.7 mm).

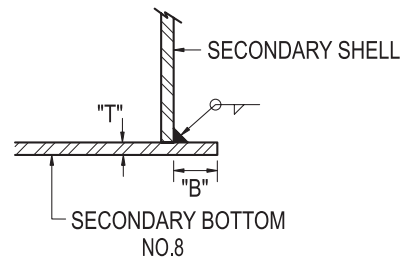

NO. 8

Welded full fillet joint  
"B" = 1/2 inch (12.7mm) or 1 1/2 T, whichever is greater.

su0168

**Figure 6.4**  
**Roof joints for vertical cylindrical tanks**

Figure 6.4 effective June 28, 2007

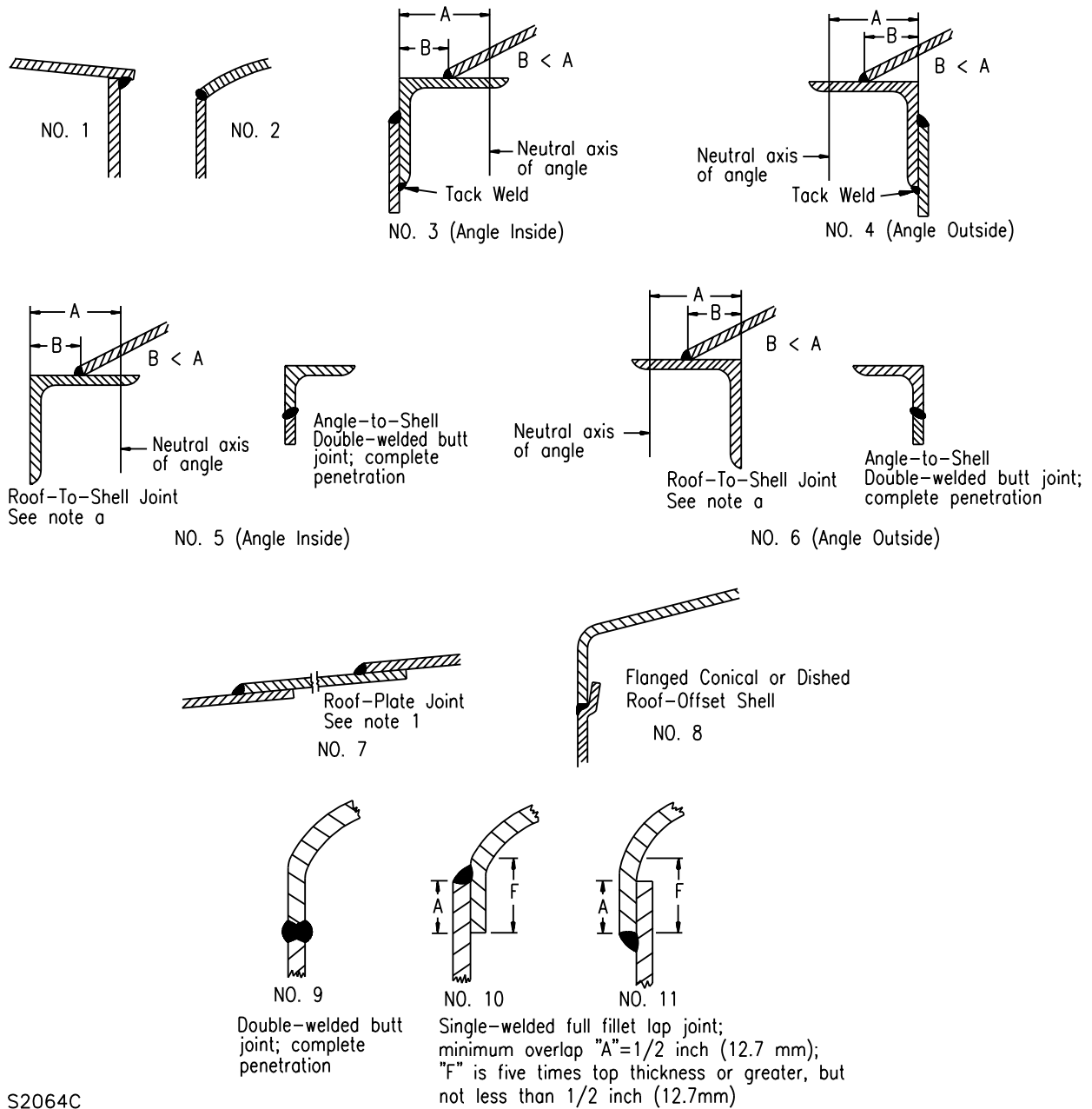

S2064C

NOTE – Unless otherwise indicated, all welds are to be full fillet welds, at least the thickest of the thinnest material.

**UL COPYRIGHTED MATERIAL –  
NOT AUTHORIZED FOR FURTHER REPRODUCTION OR  
DISTRIBUTION WITHOUT PERMISSION FROM UL**

ABDULREHMAN FAZAL || Purchased On : 1/1/19/2008 11:50:04 PM || Order Number : 081119114 || Document : 1 of 1 || ALL RIGHTS RESERVED

Figure 6.5  
Corner joints

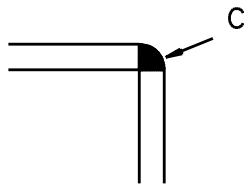

NO. 1

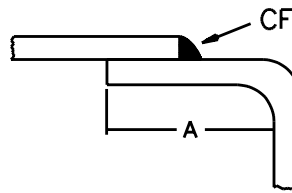

NO. 2

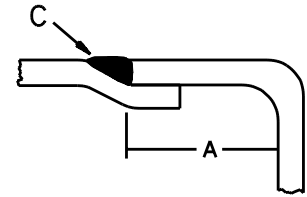

NO. 3

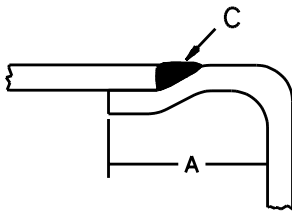

NO. 4

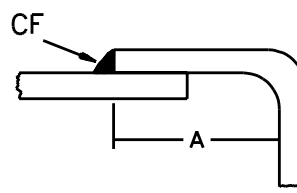

NO. 5

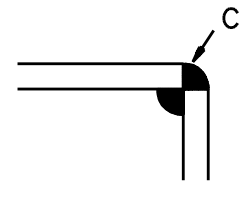

NO. 6

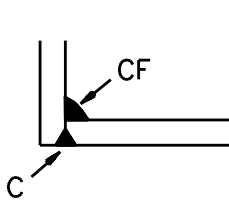

NO. 7

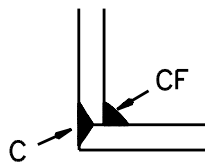

NO. 8



NO. 9



NO. 10

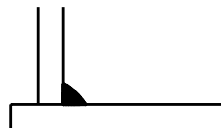

NO. 11

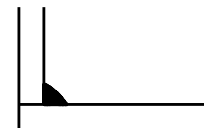

NO. 12

SM518A

C – Continuous weld.

CF – Shall be continuous full fillet welds.

A – Not less than 1/2 inch (12.7 mm).

**UL COPYRIGHTED MATERIAL –  
NOT AUTHORIZED FOR FURTHER REPRODUCTION OR  
DISTRIBUTION WITHOUT PERMISSION FROM UL**

## 7 Tank Connections

7.1 A tank connection shall be provided for each opening as illustrated in Figure 7.1 or 7.2 by:

- a) Welding a steel pipe coupling, threaded steel flange, or standard pipe nipple to the tank or
- b) A steel flange welded to a length of pipe that, in turn, is welded to the tank.

The reinforcing plates illustrated in Figure 7.2 are optional.

### Figure 7.1 Pipe connections

Revised Figure 7.1 effective December 15, 2009

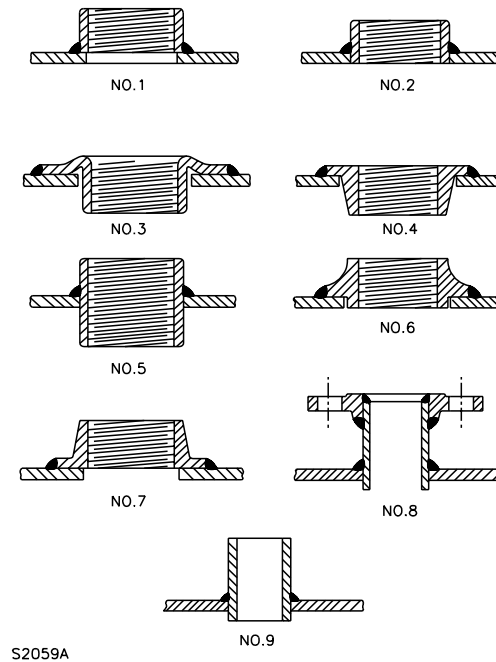

- No. 1 – Half pipe coupling.
- No. 2 – Half pipe coupling.
- No. 3 – Pressed steel, hub inside tank only.
- No. 4 – Forged steel, hub inside tank.
- No. 5 – Full pipe coupling.
- No. 6 – Forged steel, with pilot.
- No. 7 – Forged steel, without pilot.
- No. 8 – Standard pipe nipple and welding flange.
- No. 9 – Standard pipe nipple – may be unthreaded.

#### NOTES –

- 1 All welds are to be full fillet welds.
- 2 Pipe connections Nos. 8 and 9 may be trimmed flush.
- 3 Pipe connections Nos. 3, 4, 5, 8, and 9 may be seal welded on the opposite side of the weld shown.

**UL COPYRIGHTED MATERIAL –  
NOT AUTHORIZED FOR FURTHER REPRODUCTION OR  
DISTRIBUTION WITHOUT PERMISSION FROM UL**



**Figure 7.2**  
**Top or shell connections (See Table 7.1)**

Revised Figure 7.2 effective December 15, 2009

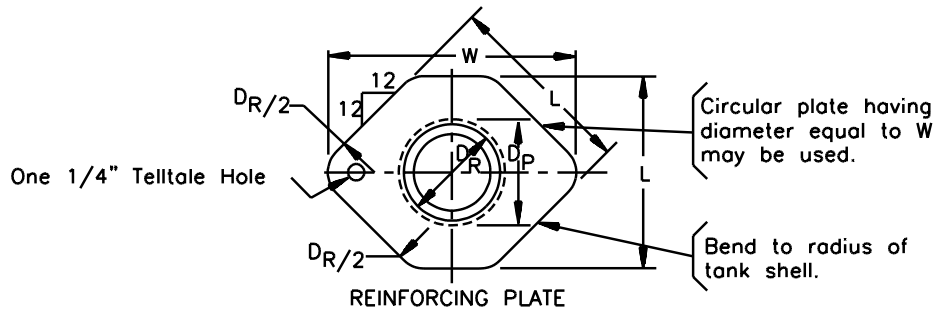
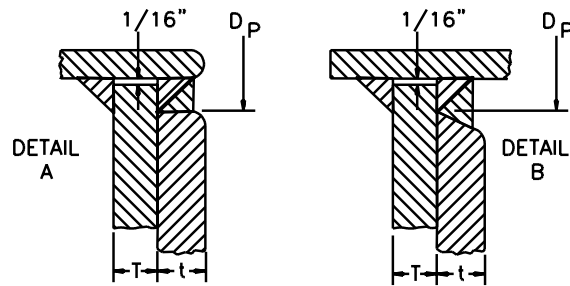
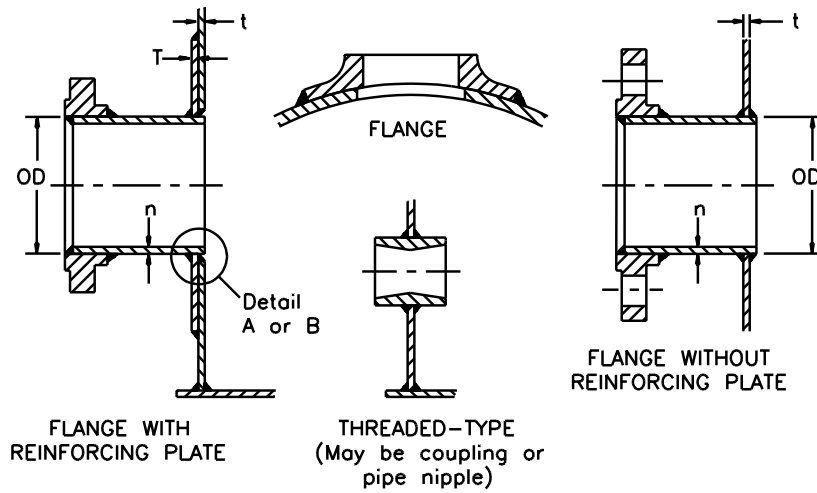

S20600

NOTES –

- 1 All welds are to be full fillet welds.
- 2  $D_p$  is the outside diameter of the pipe plus 5/8 inch (0.63 mm).
- 3 For SI units, 1 inch = 25.4 mm.

**UL COPYRIGHTED MATERIAL –**  
**NOT AUTHORIZED FOR FURTHER REPRODUCTION OR**  
**DISTRIBUTION WITHOUT PERMISSION FROM UL**

**Table 7.1**  
**Top or shell connections (See Figure 7.2)**  
**All dimensions in inches**

Table 7.1 effective June 28, 2007

Size of connection	Outside diameter of pipe	Minimum thickness of flanged connection, pipe wall <sup>a</sup> (n)	Diameter of hole in reinforcing plate (D <sub>R</sub> )	Length of side of reinforcing plate (L)	Width of reinforcing plate (W)
24	24	0.375	24-1/2	49-1/2	60
22	22	0.375	22-1/8	45-1/2	55-1/4
20	20	0.375	20-1/8	41-1/2	50-1/2
18	18	0.375	18-1/8	37-1/2	45-3/4
16	16	0.375	16-1/8	33-1/2	40-3/4
14	14	0.375	14-1/8	29-1/2	36
12	12-3/4	0.375	12-7/8	27	33
10	10-3/4	0.365	10-7/8	23	28-1/4
8	8-5/8	0.322	8-3/4	19	23-1/4
6	6-5/8	0.280	6-3/4	15-3/4	19-1/2
4	4-1/2	0.237	4-5/8	12	15-1/4
3	3-1/2	0.216	3-5/8	10-1/2	13-1/2
2	2-3/8	0.154	2-1/2	—	—
1-1/2	1.90	0.145	2	—	—

NOTE – For SI units, 1 inch = 25.4 mm.  
<sup>a</sup> Schedule 40 (standard) fittings, for sizes up to 12-inch, inclusive; for over 12- to 24-inch, inclusive, refer to the latest edition of ASTM A53/A53M, A134, A135, or A139. Pipe made from formed plate electrically butt-welded may be substituted for any of the above-mentioned pipe sections.

7.2 Connections in the roof of vertical tanks shall be as illustrated in Figure 7.1, 7.2, or 7.3. Connections in the shell of a vertical tank shall be in accordance with specifications in Figure 7.2. The reinforcing plates illustrated in Figures 7.2 and 7.3 are optional.

7.3 Hub slip-on welding and a welding-neck flange shall comply with the dimensional and material requirements for forged carbon steel flanges as specified in the Standard for Pipe Flanges and Flanged Fittings, ASME B16.5.

7.4 If a welding coupling is used, it shall comply with the Standard for Forged Steel Fittings, Socket Welding and Threaded, ASME B16.11, or the Standard Specification for Threaded Couplings, Steel, Black or Zinc-Coated (Galvanized) Welded or Seamless, for Use in Steel Pipe Joints, ASTM A865.

7.5 A threaded connection shall provide a minimum length of thread as specified in Table 7.4.

7.6 A pressed-steel-pipe-connecting fitting shall be installed with the hub section on the inside of the tank as illustrated in Detail 3 of Figure 7.1. The thickness of the flange shall not be less than specified in Table 7.1.

7.7 All pipe connection openings in a tank shall be protected with wooden or plastic plugs, metal covers, or their equivalent, to protect threads and exclude foreign matter while in storage or in transit.

**Figure 7.3**  
**Roof connections for vertical tanks (roof nozzles) [See Tables 7.2 and 7.3]**

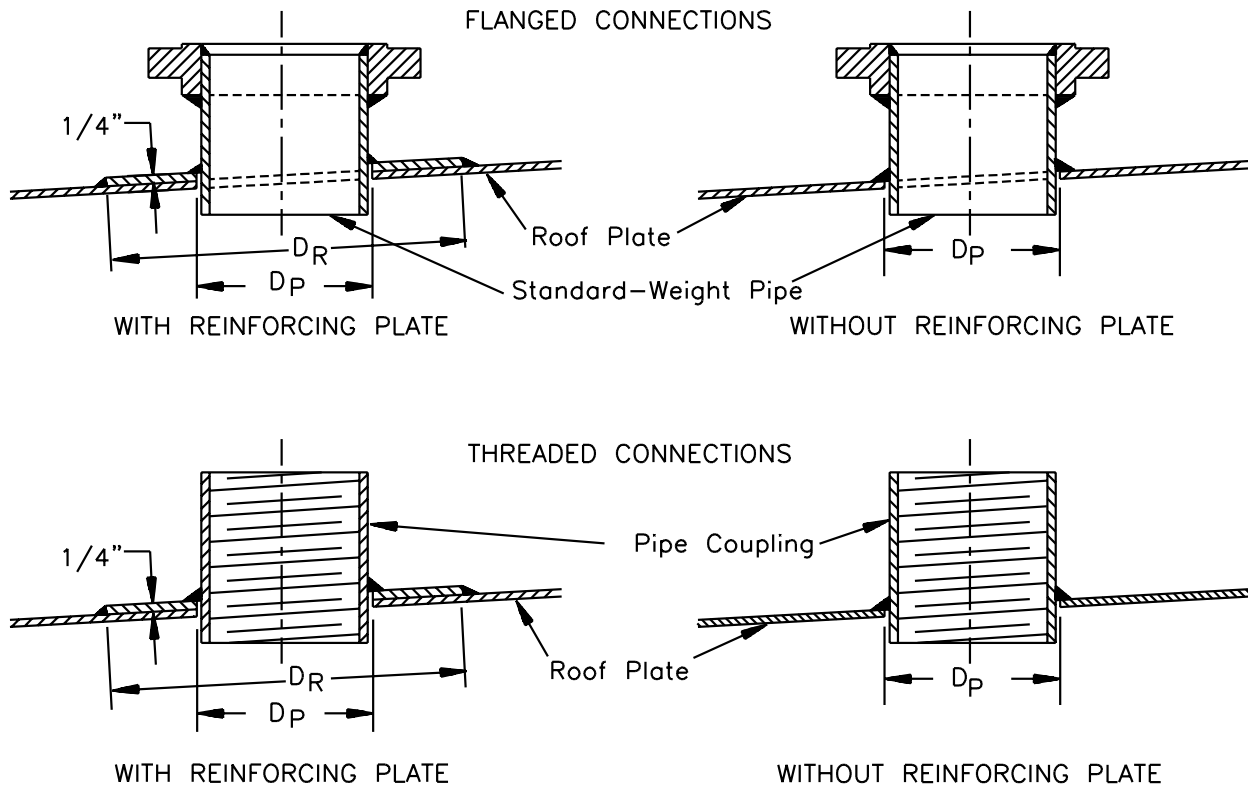

S2065F

**NOTES –**

1 When roof nozzle is used for venting purposes, it shall be trimmed flush with reinforcing plate or roof line. Axis of connections is to be vertical. All welds shall be full fillet welds.

2 If reinforcing plates are used, they shall be of a thickness equal to or greater than the roof thickness.

3 For SI units, 1 inch = 25.4 mm

**UL COPYRIGHTED MATERIAL –  
 NOT AUTHORIZED FOR FURTHER REPRODUCTION OR  
 DISTRIBUTION WITHOUT PERMISSION FROM UL**

**Table 7.2**  
**Flanged roof connections (See Figure 7.3)**

Nominal size of nozzle, inches	Maximum diameter of hole in roof plate or reinforcing plate ( $D_p$ ), inches	Outside diameter of reinforcing plate ( $D_R$ ), inches
1-1/2	DO <sup>a</sup> + 0.100	5
2	DO + 0.125	7
3	DO + 0.125	9
4	DO + 0.125	11
6	DO + 0.125	15
8	DO + 0.250	18
10	DO + 0.250	22
12	DO + 0.250	24

NOTE – For SI units, 1 inch = 25.4 mm.  
<sup>a</sup> DO is the outside diameter of the pipe neck in inches.

**Table 7.3**  
**Threaded roof connections (See Figure 7.3)**

Nominal size of nozzle, inches	Maximum diameter of hole in roof plate or reinforcing plate ( $D_p$ ), inches	Outside diameter of reinforcing plate ( $D_R$ ), inches
3/4	DO <sup>a</sup> + 0.100	4
1	DO + 0.100	4-1/2
1-1/2	DO + 0.100	5
2	DO + 0.125	7
3	DO + 0.125	9
4	DO + 0.125	11
6	DO + 0.125	15
8	DO + 0.250	18
10	DO + 0.250	22
12	DO + 0.250	24

NOTE – For SI units, 1 inch = 25.4 mm.  
<sup>a</sup> DO is the outside diameter of the coupling in inches.

**Table 7.4**  
**Minimum length of thread for threaded pipe connections**

Nominal pipe size, inches <sup>a</sup>	Minimum length of thread <sup>b</sup>		Minimum thickness of flanged section of pressed-steel fittings	
	inches	(mm)	inches	(mm)
1/8	1/4	(6.4)		
1/4	3/8	(9.5)		
3/8	3/8	(9.5)		
1/2	1/2	(12.7)		
3/4	5/8	(15.9)	0.135	(3.4)
1	5/8	(15.9)	0.150	(3.8)
1-1/4	11/16	(17.5)	0.150	(3.8)
1-1/2	3/4	(19.1)	0.150	(3.8)
2	3/4	(19.1)	0.150	(3.8)
2-1/2	1	(25.4)	0.179	(4.6)
3	1	(25.4)	0.179	(4.6)
3-1/2	1	(25.4)	0.179	(4.6)
4	1-1/8	(28.6)	0.179	(4.6)
5	1-3/16	(30.2)		
6	1-1/4	(31.7)		
8	1-3/8	(34.9)		

<sup>a</sup> Standard for Welded and Seamless Wrought Steel Pipe, ASME B36.10.  
<sup>b</sup> The threaded connection shall comply with the Standard for Pipe Threads, General Purpose (Inch), ASME B1.20.1.

## 8 Venting

8.1 Each primary containment tank and each compartment of a compartment tank shall have provision for both normal and emergency venting. The openings for these vents shall be located at the top of the tank. The interstitial (annular) space of a secondary containment tank shall have provision for emergency venting. The opening for this emergency vent shall be located at the top of the secondary containment and shall terminate vertically above the top of the primary tank. These vent openings shall be in addition to the fill, withdrawal, and liquid level gauge openings.

Revised 8.1 effective December 15, 2009

8.2 The normal venting shall be sized in accordance with Table 8.2 and shall be at least as large as the filling or withdrawal connection, whichever is larger, but in no case less than 1-1/4 inch (30 mm) nominal inside diameter.

8.3 The provision for emergency venting shall be:

- a) An opening that complies with the requirements in 8.4 and is provided for that purpose only or
- b) A manhole with cover as described in 8.8 – 8.10 and a vent opening for normal venting complying with the requirements in 8.11.

8.3 effective June 28, 2007

**UL COPYRIGHTED MATERIAL –  
NOT AUTHORIZED FOR FURTHER REPRODUCTION OR  
DISTRIBUTION WITHOUT PERMISSION FROM UL**

8.4 A vent opening that provides for emergency venting shall have a capacity not less than that specified in Table 8.1. A vent opening that provides for both emergency and normal vents shall also have a capacity not less than specified in Table 8.1. Emergency vents are not prohibited from use for normal venting of the primary tanks if the tanks are marked as specified in 48.1.1(e).

**Table 8.1**  
**Emergency venting capacity for primary tanks and interstitial space of secondary containment tanks**

Wetted surface, square feet <sup>a,b</sup>	Venting capacity, cubic feet per hour <sup>c,d</sup>	Minimum opening, nominal pipe size, inches <sup>e</sup>
20	21,100	2
30	31,600	2
40	42,100	3
50	52,700	3
60	63,200	3
70	73,700	4
80	84,200	4
90	94,800	4
100	105,000	4
120	126,000	5
140	147,000	5
160	168,000	5
180	190,000	5
200	211,000	6
250	239,000	6
300	265,000	6
350	288,000	8
400	312,000	8
500	354,000	8
600	392,000	8
700	428,000	8
800	462,000	8
900	493,000	8
1000	524,000	10
1200	557,000	10
1400	587,000	10
1600	614,000	10
1800	639,000	10
2000	662,000	10
2400	704,000	10
2800 and over	742,000	10

NOTE – Emergency venting capacity is based on atmospheric pressure of 14.7 psi and 60°F (101.4 kPa and 16°C).

<sup>a</sup> Interpolate for intermediate values.

<sup>b</sup> For SI units,  $m^2 = ft^2 \times 0.093$ .

<sup>c</sup> These values taken from NFPA 30. See 1.2.

<sup>d</sup> For SI units,  $m^3/s = ft^3/hr \times 0.03$ .

<sup>e</sup> These pipe sizes apply only to open vent pipes of the specified diameter not more than 12 inches (0.3 m) long and a gauge pressure in tank of not more than 2.5 psi (17.1 kPa). If a tank is to be equipped with a venting device or flame arrester, the vent opening is to accommodate the venting device or flame arrester sized in accordance with Column 2 of this table.

8.5 The wetted area of a horizontal tank is calculated on the basis of 75 percent of the total exposed area. A value, to the nearest whole number, for wetted areas of flat-headed horizontal tanks of various diameters and lengths are included in Table A2 of Appendix A.

8.6 The wetted area of a vertical tank is calculated on the basis of the exposed surface area of the tank shell. For vertical tanks on supports the bottom of the tank shall also be included in calculating the wetted surface area. For a vertical tank over 30 feet (9 m) high, the first 30 feet of the shell above the bottom of the tank is included in the calculation. Values, to the nearest whole number, for wetted areas of vertical tanks of various diameters and heights are included in Table A3 of Appendix A.

8.7 The wetted area of rectangular tanks is calculated on the basis of the exposed shell area excluding the top surface of the tank.

8.8 A manhole in the top of a tank, with a cover constructed so as to lift under internal pressure such that the pressure in the tank cannot exceed a gauge pressure of 2.5 psig (17.2 kPa) may serve for emergency venting. Where emergency venting is provided by such manhole and cover, the tank shall include a vent opening for normal venting in accordance with the requirements in 8.11.

8.9 Emergency venting in accordance with 8.8 may be obtained by an arrangement such that the cover of a manhole not less than 16 inches (0.4 m) in diameter can be lifted vertically not less than 1-1/2 inches (38 mm) under conditions requiring emergency venting.

8.10 A long bolt manhole intended for emergency venting shall comply with Figure 9.1, except that the number of bolts and the number of holes may be reduced to one-half the number specified in Table 9.1. The bolts shall have an unthreaded section so that the cover can lift a minimum of 1-1/2 inches (38 mm).

8.11 Each tank provided with a manhole in accordance with 8.8 shall have a vent opening in the top of the tank for normal venting. The vent opening shall be in addition to the filling and withdrawal openings, and shall not be smaller than specified in Table 8.2.

**Table 8.2**  
**Size of opening for normal venting**

Capacity of tank, U.S. gallons <sup>a</sup>	Minimum diameter, nominal pipe size, inches <sup>b</sup>
Under 2,500	1-1/4
2,500 – 3,000	1-1/2
3,001 – 10,000	2
10,001 – 20,000	2-1/2
20,001 – 35,000	3
35,001 – 50,000	4

<sup>a</sup> For SI units, gallons (U.S. gallons)  $\times$  3.8 = L.  
<sup>b</sup> See Standard for Welded and Seamless Wrought Steel Pipe, ASME B36.10.



## 9 Manholes

9.1 Except as noted in 9.3, a manhole for attachment to the top of a tank shall be as illustrated in Figure 9.1 or 9.3. A manhole attached to the shell at a location below the top of the tank or to the head of a tank shall comply with Figure 9.2 or 9.4.

Revised 9.1 effective December 15, 2009

9.1.1 Each tank which is larger than 76 inches (1.93 m) diameter shall incorporate a manhole.

Added 9.1.1 effective December 15, 2009

9.2 Except as noted in Figure 9.3, a manhole for attachment to the roof or top of a vertical cylindrical tank shall be as illustrated in Figures 9.1, 9.2 or 9.3, and Table 9.1. The reinforcing plate and handles illustrated in Figure 9.3 are optional. A manhole attached to the shell of a vertical tank or side of a horizontal tank shall be as shown in Figure 9.2 or 9.4. A manhole of the type illustrated in Figure 9.2 shall comply with Table 9.3 with regard to the minimum thickness of cover plate and bolting flange, and, if larger than 24 inches (0.6 mm) in size, shall also comply with Table 9.4 with regard to diameter of cover plate and bolt circle and the size and number of bolts.

Revised 9.2 effective December 15, 2009

**Figure 9.1**  
**Top manholes (See Table 9.1)**

Revised Figure 9.1 effective December 15, 2009

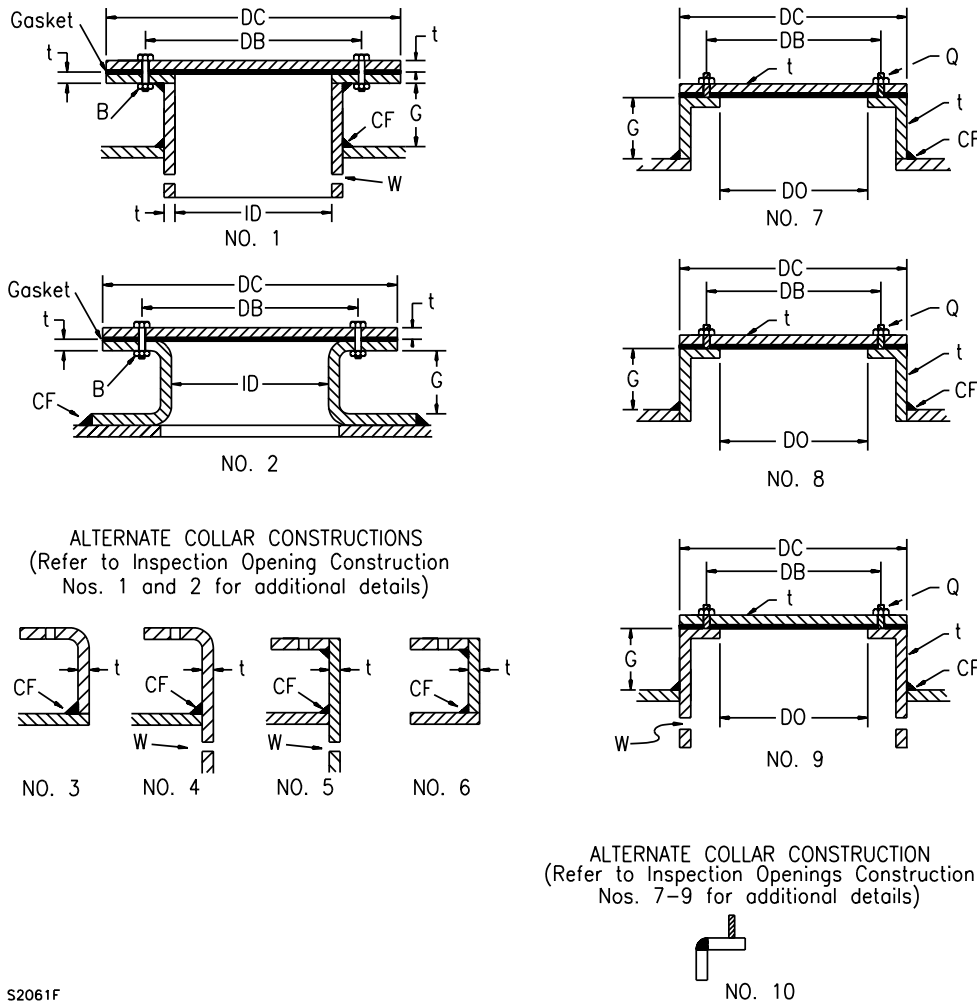

ALTERNATE COLLAR CONSTRUCTIONS  
(Refer to Inspection Opening Construction  
Nos. 1 and 2 for additional details)

ALTERNATE COLLAR CONSTRUCTION  
(Refer to Inspection Openings Construction  
Nos. 7-9 for additional details)

S2061F

t – Not less than 0.167 inch (4.24 mm) thick.

B – Minimum 1/2-inch (12.7-mm) bolts in 9/16-inch (14.3-mm) holes. Quantity per Table 9.1.

CF – Continuous full fillet weld.

G – Minimum 2 inch (50.8 mm) for tanks larger than 76 inches (1.93 m) diameter.

Q – Minimum 1/2 inch (12.7 mm) threaded studs spaced per Table 9.1.

W – Optional weep holes. Two provided. Minimum 1/4 inch (6.4 mm) diameter through hole, adjacent to the tank shell at the highest point of the tank.

NOTE – Nos. 4 and 5 may be trimmed flush as shown in No. 8.

**UL COPYRIGHTED MATERIAL –  
NOT AUTHORIZED FOR FURTHER REPRODUCTION OR  
DISTRIBUTION WITHOUT PERMISSION FROM UL**

**Table 9.1**  
**Top manholes and shell or head manholes (See Figures 9.1 and 9.2)**

Size of manhole, inches	Nominal diameter of neck (ID) or opening (DO), inches	Nominal diameter of cover plate (DC), inches	Nominal diameter of bolt circle (DB), inches	Minimum number of bolts
16	16	20-1/2	19	16
18	18	22-1/2	21	18
20	20	24-1/2	23	20
22	22	26-1/2	25	22
24	24	28-1/2	27	24
30	30	35-1/2	33	42
36	36	41-1/2	39	52

**Figure 9.2**  
**Shell or head manholes (Horizontal Tanks – See Table 9.1; Vertical Tanks – See Table 9.3)**

Revised Figure 9.2 effective December 15, 2009

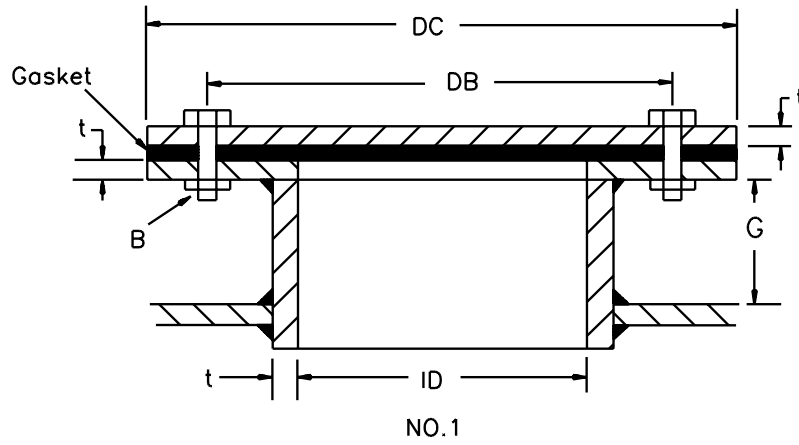

ALTERNATE DESIGNS

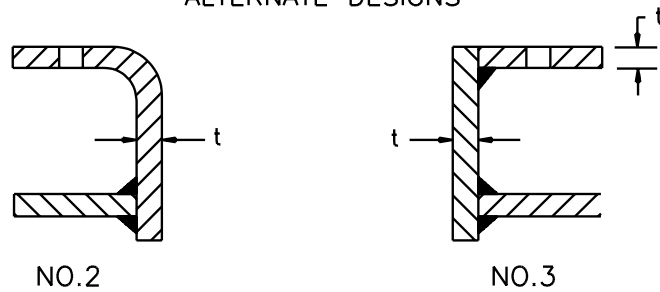

S2062C

t – Not less than 0.240 inch (6.1 mm) thick.

B – Minimum 1/2-inch (12.7-mm) bolts in 9/16-inch (14.3-mm) holes.

G – Minimum 2 inches (50.8 mm) for tanks larger than 76 inches (1.93 m) diameter.

NOTE – All welds are to be full fillet welds.

**UL COPYRIGHTED MATERIAL –  
 NOT AUTHORIZED FOR FURTHER REPRODUCTION OR  
 DISTRIBUTION WITHOUT PERMISSION FROM UL**

**Table 9.2**  
**Roof manholes for vertical tanks (See Figure 9.3)**

Size of manhole, inches <sup>a</sup>	Diameter of neck (ID), inches <sup>a</sup>	Diameter of cover plate (D <sub>C</sub> ), inches <sup>a</sup>	Diameter of bolt circle (D <sub>B</sub> ), inches <sup>a</sup>	Minimum number of bolts	Diameter of hole in roof plate or reinforcing plate (D <sub>P</sub> ), inches <sup>a</sup>	Outside diameter of reinforcing plate (D <sub>R</sub> ), inches <sup>a</sup>
16	16	20-1/2	19	16	16-5/8	38
18	18	22-1/2	21	18	18-5/8	40
20	20	24-1/2	23	20	20-5/8	42
22	22	26-1/2	25	22	22-5/8	44
24	24	28-1/2	27	24	24-5/8	46

<sup>a</sup> For SI units, 1 inch = 25.4 mm.

**Table 9.3**  
**Thickness of shell manhole cover plate and bolting flange (See Figures 9.2 and 9.4)**  
**All dimensions are in inches unless otherwise stated**

Maximum tank height, feet <sup>a</sup>	Equivalent pressure <sup>b</sup> , pounds per square inch <sup>c</sup>	Minimum thickness of cover plate			Minimum thickness of bolting flange after finishing		
		16-inch manhole <sup>d</sup>	18-inch manhole <sup>d</sup>	20-inch manhole <sup>d</sup>	16-inch manhole <sup>d</sup>	18-inch manhole <sup>d</sup>	20-inch manhole <sup>d</sup>
21	9.1	1/4	1/4	5/16	1/4	1/4	1/4
27	11.7	5/16	5/16	3/8	1/4	1/4	1/4
32	13.9	5/16	5/16	3/8	1/4	1/4	1/4
35	15.2	5/16	3/8	7/16	1/4	1/4	5/16
		24-inch manhole <sup>d</sup>	30-inch manhole <sup>d</sup>	36-inch manhole <sup>d</sup>	24-inch manhole <sup>d</sup>	30-inch manhole <sup>d</sup>	36-inch manhole <sup>d</sup>
21	9.1	3/8	7/16	1/2	1/4	5/16	3/8
27	11.7	7/16	1/2	5/8	5/16	3/8	7/16
32	13.9	7/16	9/16	9/16	5/16	7/16	1/2
35	15.2	1/2	5/8	11/16	3/8	1/2	9/16

<sup>a</sup> For SI units, 1 foot = 0.3 m.  
<sup>b</sup> Equivalent pressure is based on water loading.  
<sup>c</sup> For SI units, a gauge pressure of 1 psi = 6.9 kPa.  
<sup>d</sup> For SI units, 1 inch = 25.4 mm.

9.3 A cover for a manhole in the top of a tank may be of the self-closing type or may be secured by long bolts so that the cover can lift under internal pressure. See 8.10.

9.4 A manhole-cover joint shall be provided with a ring or face gasket of material determined to be acceptable for use with flammable liquids and having a thickness of not less than 1/8 inch (3.2 mm).

Revised 9.4 effective December 15, 2009

**UL COPYRIGHTED MATERIAL –  
NOT AUTHORIZED FOR FURTHER REPRODUCTION OR  
DISTRIBUTION WITHOUT PERMISSION FROM UL**

**Figure 9.3**  
**Roof manholes for vertical tanks (See Table 9.2)**

Revised Figure 9.3 effective December 15, 2009

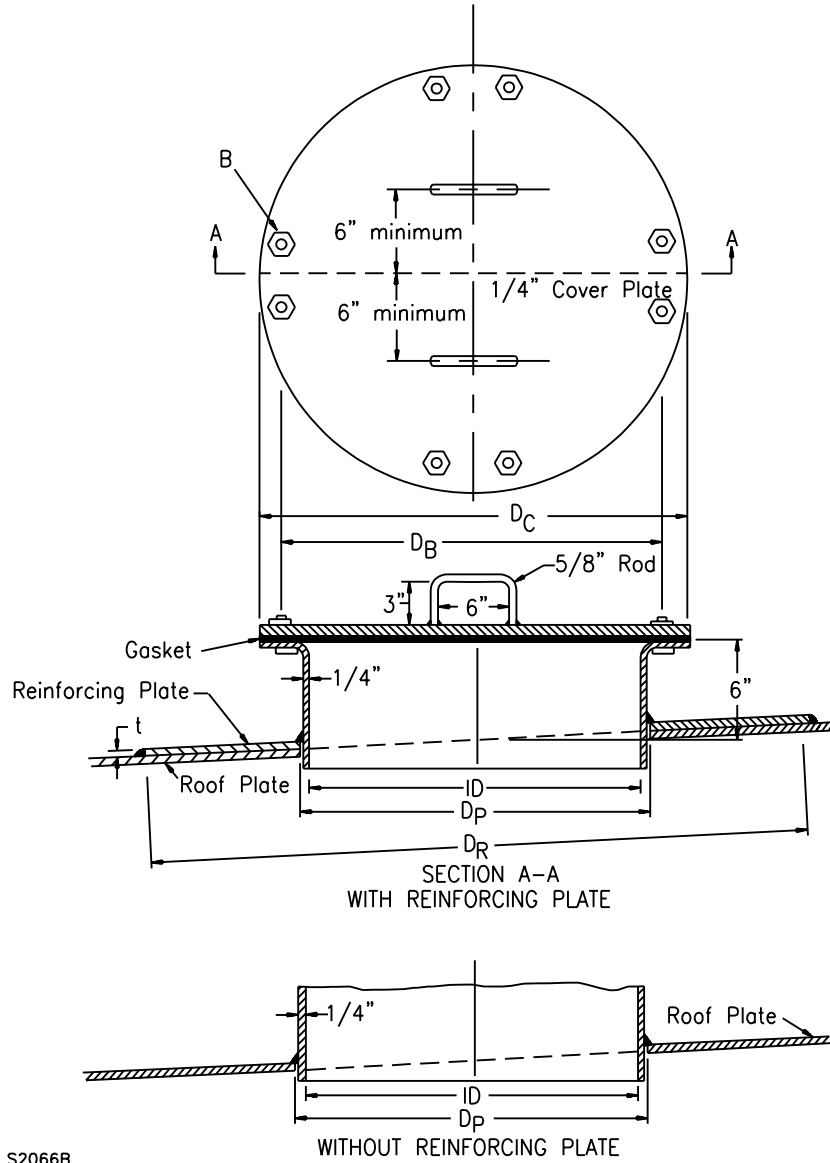

S2066B

$t = 1/4$  inch

NOTES –

- 1 The manhole construction may be trimmed flush.
- 2 All welds are to be full fillet welds.
- 3 For SI units, 1 inch = 25.4 mm.

ABDULREHMAN FAZAL || Purchased On : 1/1/19/2008 11:50:04 PM || Order Number : 081119114 || Document : 1 of 1 || ALL RIGHTS RESERVED

**UL COPYRIGHTED MATERIAL –  
 NOT AUTHORIZED FOR FURTHER REPRODUCTION OR  
 DISTRIBUTION WITHOUT PERMISSION FROM UL**

**Figure 9.4**  
**Shell manholes for vertical tanks (See Tables 9.3 and 9.4)**

Revised Figure 9.4 effective December 15, 2009

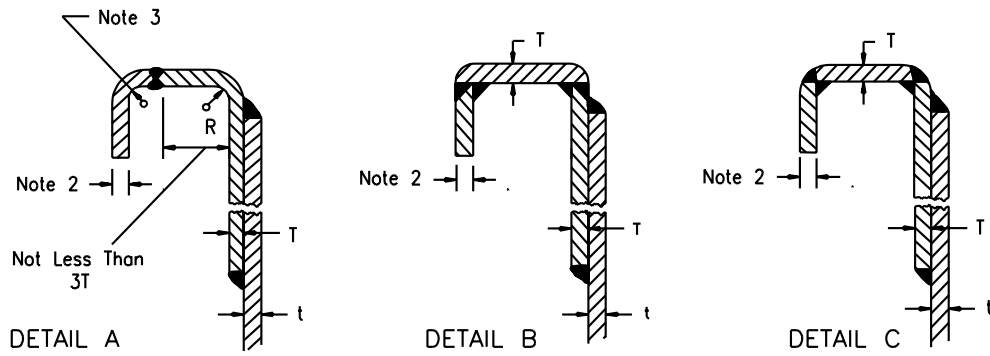
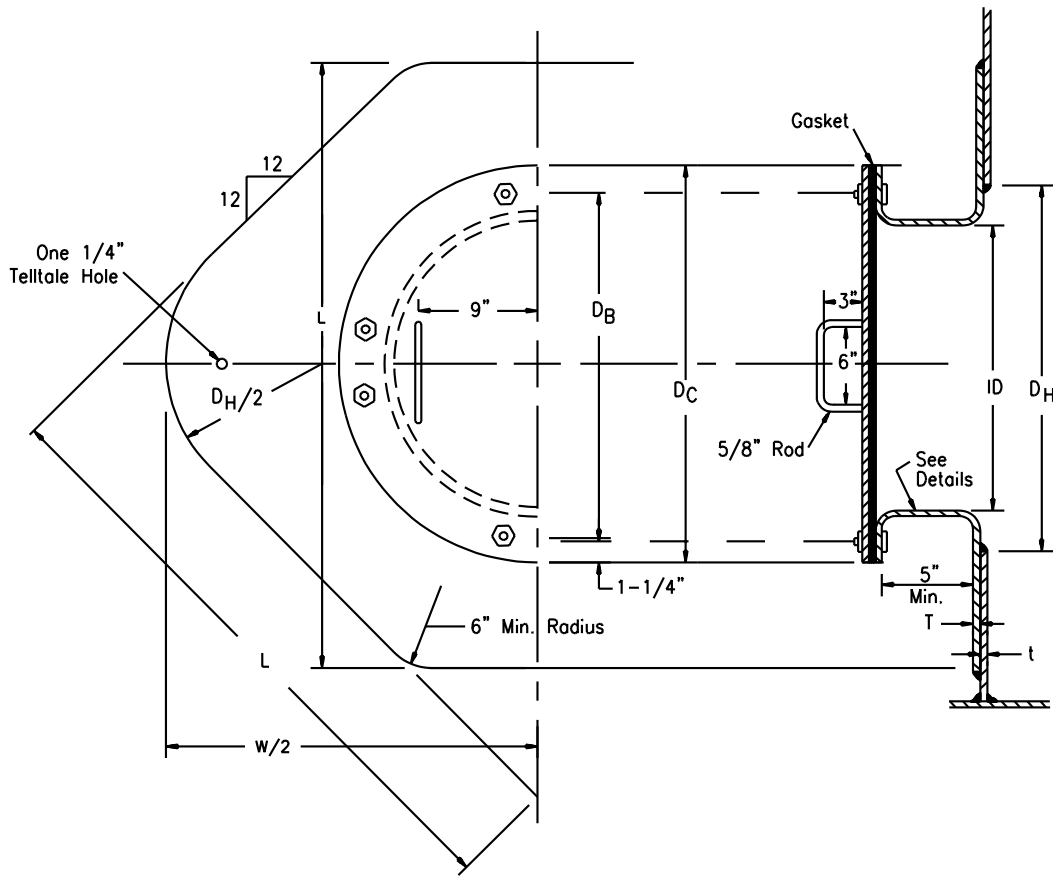

S2067B

NOTES –

1 All welds are to be full fillet welds.

2 For SI units, 1 inch = 25.4 mm.

**UL COPYRIGHTED MATERIAL –  
 NOT AUTHORIZED FOR FURTHER REPRODUCTION OR  
 DISTRIBUTION WITHOUT PERMISSION FROM UL**

**Table 9.4**  
**Shell manhole dimensions (See Figure 9.4)**  
**All dimensions are in inches unless otherwise stated**

Thickness of shell and manhole attachment flange (t) and (T)	Approximate radius (R)	Attachment flange		Frame using constant-diameter ring die		Built-up frame or frame using constant diameter plug die	
		Length of side (L)	Width (W)	Inside diameter of manhole frame (ID)	Maximum diameter of hole in shell (D <sub>H</sub> )	Inside diameter of manhole frame (ID)	Maximum diameter of hole in shell (D <sub>H</sub> )
16-Inch Shell Manhole							
0.167	3/16	38	45-1/2	18-5/8	20-1/4	16	17-3/4
1/4	1/4	38	45-1/2	18-1/2	20-1/2	16	18
Diameter of bolt circle D <sub>B</sub> = 22-1/4 inches, Diameter of cover plate D <sub>C</sub> = 22-3/4 inches 20-3/4 inch diameter bolts in 7/8 inch diameter holes							
18-Inch Shell Manhole							
0.167	3/16	42	50-1/2	20-5/8	22-1/4	18	19-3/4
1/4	1/4	42	50-1/2	20-1/2	22-1/2	18	20
Diameter of bolt circle D <sub>B</sub> = 24-1/4 inches, Diameter of cover plate D <sub>C</sub> = 26-3/4 inches 20-3/4 inch diameter bolts in 7/8 inch diameter holes							
20-Inch Shell Manhole							
0.167	3/16	46	55	22-5/8	24-1/4	20	21-3/4
1/4	1/4	46	55	22-1/2	24-1/2	20	22
Diameter of bolt circle D <sub>B</sub> = 26-1/4 inches, Diameter of cover plate D <sub>C</sub> = 28-3/4 inches 28-3/4 inch diameter bolts in 7/8 inch diameter holes							
22-inch Shell Manhole							
0.167	3/16	50	60	24-5/8	26-1/4	22	23-3/4
1/4	1/4	50	60	24-1/2	26-1/2	22	24
Diameter of bolt circle D <sub>B</sub> = 28-1/4 inches, Diameter of cover plate D <sub>C</sub> = 30-3/4 inches. 28-3/4 inch diameter bolts in 7/8 inch diameter holes							
24-Inch Shell Manhole							
0.167	3/16	54	65	26-5/8	28-1/4	24	25-3/4
1/4	1/4	54	64-3/4	26-1/2	28-1/2	24	26
Diameter of bolt circle D <sub>B</sub> = 30-1/4 inches, Diameter of cover plate D <sub>C</sub> = 32-3/4 inches 28-3/4 inch diameter bolts in 7/8 inch diameter holes							
30-Inch Shell Manhole							
0.167	3/16	66	79-1/4	32-5/8	34-1/4	30	31-3/4
1/4	1/4	66	79-1/4	32-1/2	34-1/2	30	32
Diameter of bolt circle D <sub>B</sub> = 36-1/4 inches, Diameter of cover plate D <sub>C</sub> = 38-3/4 inches 42-3/4 inch diameter bolts in 7/8 inch diameter holes							
36-Inch Shell Manhole							
0.167	3/16	78	93-3/4	38-5/8	40-1/4	36	37-3/4
1/4	1/4	78	93-3/4	38-1/2	40-1/2	36	38
Diameter of bolt circle D <sub>B</sub> = 42-1/4 inches, Diameter of cover plate D <sub>C</sub> = 44-3/4 inches 42-3/4 inch diameter bolts in 7/8 inch diameter holes							
NOTE – For SI units, 1 inch = 25.4 mm.							



## 10 Fill, Drain, and Gauge Openings

10.1 In addition to vent openings each tank and each compartment of a multicompartment tank shall be provided with fittings to accommodate filling, inventory control and product withdrawal.

## 11 Painting

11.1 Unless made of stainless steel, a tank, after having been tested and found free from leakage, shall be given at least one coat of paint on exposed surfaces to protect them from atmospheric corrosion during storage at the factory premises and in transit to the installation site.

## PART I – PRIMARY CONTAINMENT TANKS

### HORIZONTAL CYLINDRICAL CONSTRUCTIONS

#### 12 General

12.1 In addition to complying with the applicable requirements in Sections 4 – 11 for all tank constructions, primary containment horizontal cylindrical tanks shall also comply with the requirements in Construction, Section 13.

#### 13 Construction

##### 13.1 Capacities and dimensions

13.1.1 A horizontal tank shall not exceed either the maximum capacity or the diameter for the corresponding thickness of steel specified in Table 13.1.

**Table 13.1**  
**Minimum steel thickness – horizontal tanks**

Revised Table 13.1 effective December 15, 2009

Actual capacity, U.S. gallons (kL)		Maximum diameter, inches (m)	Minimum steel thickness, inch (mm)	
			Carbon steel	Stainless steel
550 or less	(2.08)	48 (1.22)	0.093 (2.36)	0.071 (1.80)
551 – 1100	(2.14 – 4.16)	64 (1.63)	0.123 (3.12)	0.086 (2.18)
1101 – 9000	(4.17 – 34.07)	76 (1.93)	0.167 (4.24)	0.115 (2.92)
1101 – 35,000	(4.17 – 132.49)	144 (3.66)	0.240 (6.10)	0.158 (4.01)
35,001 – 50,000	(132.50 – 189.27)	144 (3.66)	0.365 (9.27)	0.240 (6.10)
50,001 – 75,000	(189.27 – 283.6)	156 (3.97)	0.365 (9.27)	0.365 (9.27)

13.1.2 The overall length of a horizontal tank shall not be greater than six times its diameter. Tank diameters exceeding 144 inches (3.66 meters) shall be further limited to a maximum of 72 feet (21.95 meters) in cylinder length.

Revised 13.1.2 effective December 15, 2009

**UL COPYRIGHTED MATERIAL –  
NOT AUTHORIZED FOR FURTHER REPRODUCTION OR  
DISTRIBUTION WITHOUT PERMISSION FROM UL**

## 13.2 Steel thickness

13.2.1 A horizontal tank shall be constructed from steel not thinner than specified in Table 13.1 for its capacity and diameter.

## 13.3 Heads and head joints

13.3.1 A head of a horizontal tank shall be constructed of not more than three pieces for tank diameters of 48 to 96 inches (1.2 to 2.4 m); and four pieces for diameters of 97 to 156 inches (2.42 to 3.9 m). When two or more pieces are used, joints shall be one of the shell joint constructions described in Figure 6.1, except joint No. 6 shall not be used.

Revised 13.3.1 effective December 15, 2009

13.3.2 A head of a horizontal tank shall be flat flanged or flanged and dished.

13.3.2 effective June 28, 2007

13.3.3 A flanged flat head of a horizontal tank more than 72 inches (1.8 m) in diameter shall be made of steel not less than 5/16 inch (7.9 mm) thick or it shall be braced in accordance with Figure 13.1.

**Figure 13.1**  
**Bracings for head and bulkheads (See Table 13.2)**

Revised Figure 13.1 effective December 15, 2009

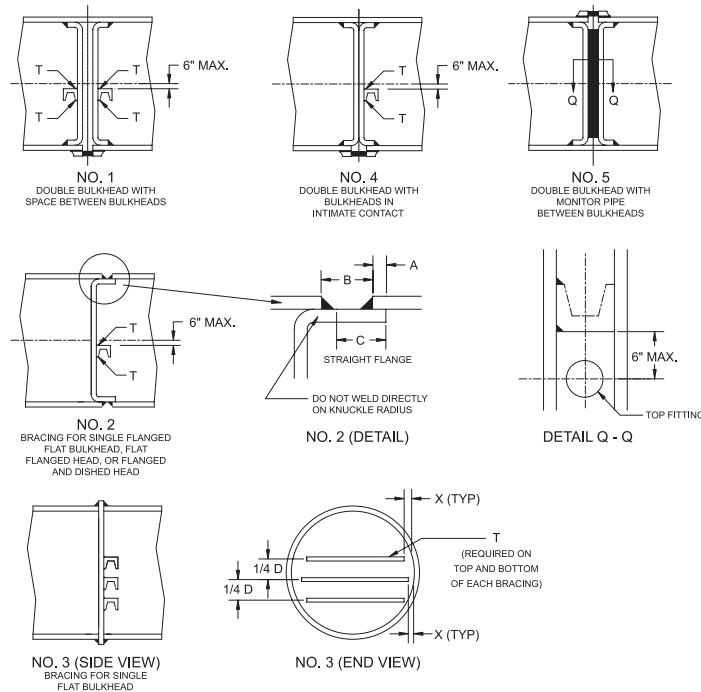

S5623

- A – 1/2 inch (12.7 mm) minimum
- B – 3/4 inch (19.1 mm) minimum
- C – 1-1/4 inch (31.8 mm) minimum
- T – Tack welds, not over 12 inches (0.3 m) apart
- V – Bracing
- D – Tank diameter
- X – 4 inches (102 mm) maximum from shell

**NOTES –**

- 1 See Table 13.2 for bracing of flanged flat heads and bulkheads (Nos. 1 and 2) and Table 13.4 for bracing of unflanged flat bulkheads (No. 3).
- 2 For No. 1, the testing flange may be located on the top of the tank.
- 3 For No. 1 through No. 4 bracing may be oriented in any direction, but must be placed within 6 inches (0.15 m) of center of head or bulkhead. Bracing for No. 5 must be vertical.

**UL COPYRIGHTED MATERIAL –  
 NOT AUTHORIZED FOR FURTHER REPRODUCTION OR  
 DISTRIBUTION WITHOUT PERMISSION FROM UL**

**Table 13.2**  
**Bracing for flanged flat heads and bulkheads (See Figure 13.1)**

Diameter of head, inches <sup>a</sup>	I-beams		Channels	
	Inches <sup>a</sup>	Pounds <sup>b</sup>	Inches <sup>a</sup>	Pounds <sup>b</sup>
72 to 84	3	5.7	3	4.1
85 to 96	3	5.7	4	5.4
97 to 108	4	7.7	5	6.7
109 to 120	5	10	5	6.7
121 to 132	5	10	6	8.2
133 to 144	5	10	6	8.2

<sup>a</sup> For SI units, 1 inch = 25.4 mm.  
<sup>b</sup> For SI units, 1 kg = 2.2 pounds.

13.3.4 A flanged flat head shall have an inside knuckle radius equal to at least 2.0 times the head thickness.

13.3.4 effective June 28, 2007

13.3.5 The depth of dish of a dished head shall not be less than that specified in Table 13.3.

13.3.6 The head of a tank greater than 144 inches (3.66 meters) in diameter shall be flanged and dished, with a dished radius equal to the tank diameter, and a knuckle radius of at least 1/10 of the tank diameter.

Added 13.3.6 effective December 15, 2009

**Table 13.3**  
**Dished heads – depth of dish**

Revised Table 13.3 effective December 15, 2009

Diameter		Minimum depth		Diameter		Minimum depth	
Inches	m	Inches	mm	Inches	m	Inches	mm
Up to 60	(Up to 1.52)	1-1/2	(38)	97 – 108	(2.46 – 2.74)	4-1/2	(114)
61 – 72	(1.55 – 1.83)	2	(51)	109 – 120	(2.77 – 3.05)	5-1/2	(140)
73 – 84	(1.85 – 2.13)	2-1/2	(64)	121 – 132	(3.07 – 3.35)	7	(178)
85 – 96	(2.16 – 2.44)	3-1/2	(89)	133 – 144	(3.38 – 3.66)	8	(203)
97 – 108	(2.46 – 2.74)	4-1/2	(114)	144 – 156	(3.58 – 3.96)	20	(508)

**UL COPYRIGHTED MATERIAL –  
 NOT AUTHORIZED FOR FURTHER REPRODUCTION OR  
 DISTRIBUTION WITHOUT PERMISSION FROM UL**

### 13.4 Compartment tank construction

13.4.1 A bulkhead of a compartment tank shall be constructed so that leakage through any bulkhead joints will not be directed from one compartment to another. See Figure 13.1 for acceptable bulkhead constructions. Bulkheads are not allowed in tanks over 144 inches in diameter.

Revised 13.4.1 effective December 15, 2009

13.4.2 A bulkhead of a single or double bulkhead tank, shall be constructed of one piece for tank diameters under 72 inches, of not more than two pieces for tank diameters from 72 to 96 inches, and three pieces for diameters of from 97 to 144 inches (2.42 to 3.6 m). When two or more pieces are used, joints shall be in accordance with Figure 6.1 Joints No. 1 or No. 2.

Revised 13.4.2 effective December 15, 2009

**Figure 13.2**  
**Bulkheads for compartment tanks**

Figure 13.2 deleted effective December 15, 2009

ABDULREHMAN FAZAL || Purchased On : 1/1/19/2008 11:50:04 PM || Order Number : 081119114 || Document : 1 of 1 || ALL RIGHTS RESERVED

**UL COPYRIGHTED MATERIAL –  
NOT AUTHORIZED FOR FURTHER REPRODUCTION OR  
DISTRIBUTION WITHOUT PERMISSION FROM UL**

13.4.3 The minimum thickness of metal used for a bulkhead shall not be less than 0.167 inch (4.24 mm) for diameters of 76 inches (1.9 m) or less and 1/4 inch (6.4 mm) for diameters of more than 76 inches.

13.4.4 An unflanged flat bulkhead of a compartment tank shall be braced in accordance with Figure 13.1 and Table 13.4.

Revised 13.4.4 effective December 15, 2009

**Table 13.4**  
**Bracing for unflanged flat heads and bulkheads (See Figure 13.1)**

Diameter of head, inches <sup>a</sup>	Channels		Angles, inches <sup>a</sup>					
	Inches	Pounds <sup>b</sup>						
Up to 60	3	4.1	2	× 2	× 3/8	or 2-1/2	× 2-1/2	× 1/4
61 to 72	3	4.1	3	× 3	× 7/16	or 3-1/2	× 3-1/2	× 5/16
73 to 84	4	5.4	3-1/2	× 3-1/2	× 1/2	or 4	× 4	× 3/8
85 to 96	5	6.7	4	× 4	× 1/2	or 5	× 3-1/2	× 3/8 <sup>c</sup>
97 to 108	5	6.7	4	× 4	× 3/4	or 6	× 4	× 3/8 <sup>c</sup>
109 to 120	6	8.2	5	× 5	× 5/8	or 6	× 4	× 1/2 <sup>c</sup>
121 to 132	7	9.8	5	× 5	× 3/4	or 6	× 4	× 9/16 <sup>c</sup>
133 to 144	7	9.8	5	× 5	× 3/4	or 6	× 4	× 9/16 <sup>c</sup>

<sup>a</sup> For SI units, 1 inch = 25.4 mm.  
<sup>b</sup> For SI units, 1 kg = 2.2 pounds.  
<sup>c</sup> Short leg of angle welded to head.

13.4.5 A flanged flat bulkhead of a compartment tank more than 72 inches (1.8 m) in diameter shall be made of not less than 5/16 inch (7.9 mm) thick material or it shall be braced in accordance with Figure 13.1 and Table 13.2.

## VERTICAL CYLINDRICAL CONSTRUCTIONS

### 14 General

14.1 In addition to complying with the applicable requirements in Sections 4 – 11 for all tank constructions, primary containment vertical cylindrical tanks shall also comply with the requirements in Construction, Section 15.

## 15 Construction

### 15.1 Capacities and dimensions

15.1.1 The minimum diameter of a vertical tank shall not be less than one-quarter of its height.

15.1.2 The shell height of a vertical tank shall not be more than 50 feet ( 15.24 m), and the diameter shall not exceed 14 feet (4.27 m).

Revised 15.1.2 effective December 15, 2009

15.1.3 Deleted effective December 15, 2009

### 15.2 Steel thickness

15.2.1 A vertical tank shall be constructed from steel not thinner than specified in Table 15.1.

**Table 15.1**  
**Minimum steel thickness – vertical tanks**

Actual capacity, U.S. gallons (kL)	Carbon steel sheet thickness, inch (mm)			Stainless steel sheet thickness, inch (mm)		
	Shell	Bottom	Top <sup>a</sup>	Shell	Bottom	Top
1100 or less (4.16 or less)	0.093 (2.36)	0.093 (2.36)	0.093 (2.36)	0.086 (2.18)	0.086 (2.18)	0.086 (2.18)
More than 1100 (more than 4.16)	0.167 (4.24) <sup>b</sup>	0.240 (6.10)	0.123 (3.12)	0.115 (2.92) <sup>c</sup>	0.158 (4.01)	0.086 (2.18)

<sup>a</sup> See 15.3.3.  
<sup>b</sup> For a tank more than 25 feet (7.5 m) in height, all parts of the shell located more than 25 feet below the top edge of the shell shall not be less than 0.240 inch (6.1 mm) thick.  
<sup>c</sup> For a tank more than 25 feet (7.5 m) in height, all parts of the shell located more than 25 feet below the top edge of the shell shall not be less than 0.158 inch (401 mm) thick.

### 15.3 Tank top (roof)

15.3.1 The top of a vertical cylindrical tank shall be constructed of not more than four pieces. If two or more pieces are used, joints shall be one of the shell joint constructions described in Figure 6.1.

15.3.2 The top of a single wall and outer shell of a secondary containment vertical tank shall be dished or conical.

*Exception: Flat top roofs for vertical tanks are acceptable provided there is no leakage found during the Tank Leakage Test, Section 39, which is conducted after the Top Load Test, Section 41.*

15.3.3 The height of a conical top shall not be less than one-sixth of the radius of the tank when the top is made of steel less than 0.167 inch (4.24 mm) thick and shall not be less than one-twelfth of the radius of the tank when the top is made of steel not less than 0.167 inch thick. A dished head shall have a depth of dish not less than that specified in Table 13.3.



## 15.4 Tank bottom (floor)

15.4.1 The bottom of a vertical cylindrical tank shall be constructed of not more than four pieces. If two or more pieces are used, joints shall be one of the shell joint constructions described in Figure 6.1, except that joint No. 6 shall not be used.

15.4.2 Vertical cylindrical tanks elevated on supports shall meet the requirements of paragraph 30.3.

Added 15.4.2 effective December 15, 2009

## RECTANGULAR CONSTRUCTIONS

### 16 General

16.1 In addition to complying with the applicable requirements in Sections 4 – 12 for all tank constructions, primary containment rectangular tanks shall also comply with the requirements in Construction, Section 17, and Performance, Section 18.

### 17 Construction

#### 17.1 General

17.1.1 Stiffening bars may be attached to the tank wall either by intermittent or continuous welding and may be placed on the inside or outside of the tank walls.

17.1.2 Tie rods may be used inside of the tank.

17.1.3 Baffles shall be intermittently welded or continuously welded on the inside of the tank.

#### 17.2 Steel thickness

17.2.1 Tanks of this type shall be constructed from steel not thinner than 0.093 inch (2.36 mm) if of carbon steel or 0.071 inch (1.80 mm) if of stainless steel.

### 18 Performance

#### 18.1 Hydrostatic strength test

18.1.1 The tank shall be tested to demonstrate that the strength of the assembly and the welded joints are in accordance with these requirements.

18.1.2 The tank shall not rupture or leak when subjected to the Hydrostatic Strength Test, Section 40.

## 18.2 Top load test

18.2.1 After being subjected to the Top Load Test, Section 41, the tank shall then be subjected to the Leakage Test, Section 39, and shall not leak.

## PART II – SECONDARY CONTAINMENT TANKS

### ALL SECONDARY CONTAINMENT TANK CONSTRUCTIONS

#### 19 General

19.1 All secondary containment tanks shall be constructed to provide a means for monitoring leakage into the interstitial (annular) space through either the interior or exterior walls, and so that liquid can flow freely within the interstitial space to the point of monitoring.

### HORIZONTAL CYLINDRICAL CONSTRUCTIONS

#### 20 General

20.1 In addition to complying with the applicable requirements in Sections 4 – 11 for all tank constructions, secondary containment horizontal cylindrical tanks shall also comply with the requirements in Construction, Section 21.

#### 21 Construction

21.1 The primary containment tank shell of a secondary containment tank shall be constructed in accordance with Part I – Primary Containment Tanks, Horizontal Cylindrical Constructions, Sections 12 and 13.

21.2 The outer shell and head of a secondary containment tank shall meet the requirements specified for Part I – Primary Containment Tanks, Horizontal Cylindrical Constructions, Sections 12 and 13, except that a direct contact secondary shell and heads may wrap a minimum of 300 degrees or provide a minimum of 95 percent containment, whichever is greater.

21.2 effective June 28, 2007

21.3 A secondary tank shell that is not in direct contact with the primary tank shall have standoffs positioned as shown in Figure 21.1. This construction is not allowed for tanks over 144 inches in diameter.

Revised 21.3 effective December 15, 2009

Figure 21.1  
Secondary containment tank standoff positioning

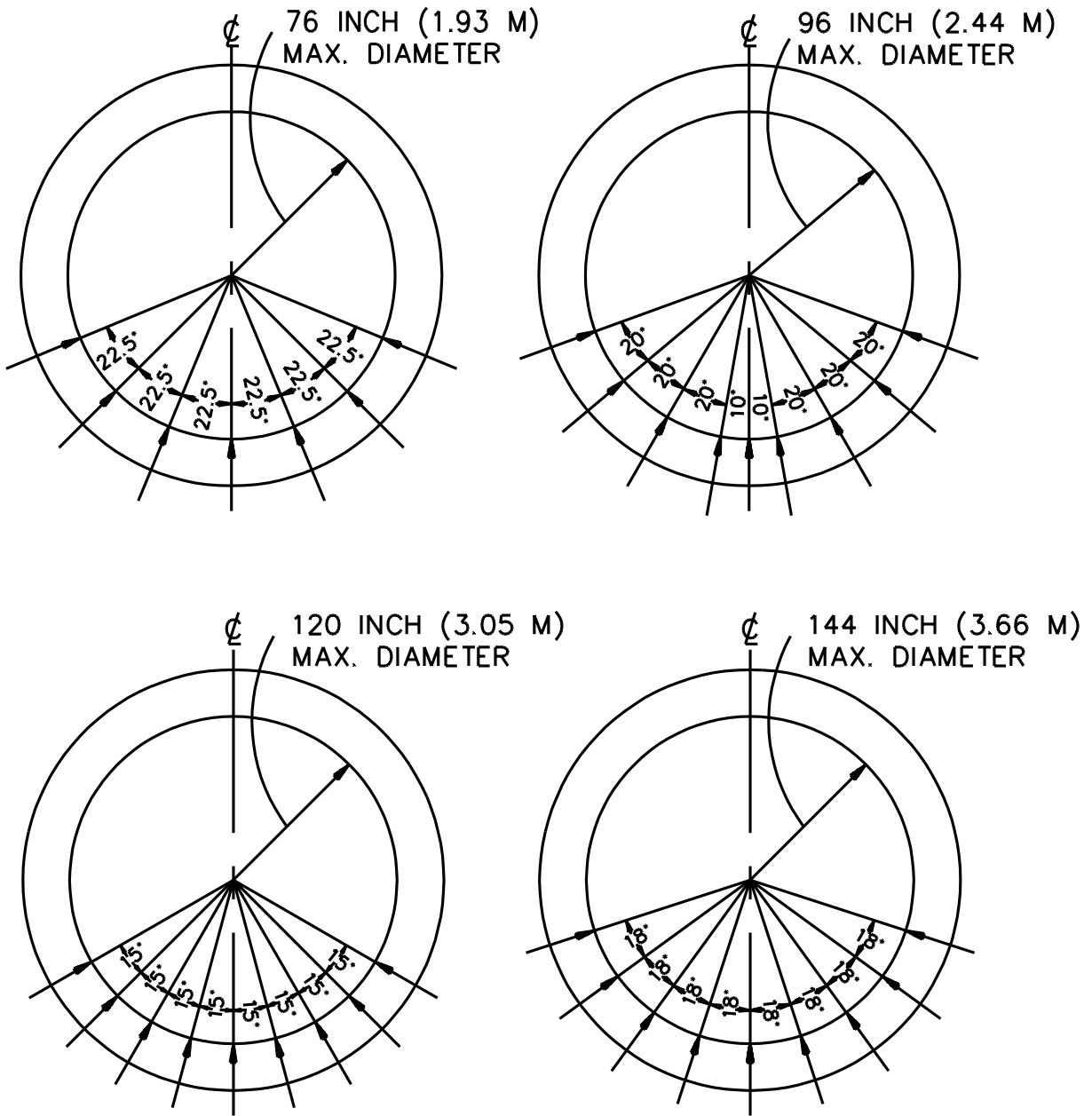

S3610E

ABDULREHMAN FAZAL || Purchased On : 1/1/19/2008 11:50:04 PM || Order Number : 081119114 || Document : 1 of 1 || ALL RIGHTS RESERVED

UL COPYRIGHTED MATERIAL –  
NOT AUTHORIZED FOR FURTHER REPRODUCTION OR  
DISTRIBUTION WITHOUT PERMISSION FROM UL

21.4 The standoffs shown in Figure 21.1 may be oriented with the web either parallel or perpendicular to the shell and shall be a minimum of 3 by 1-1/2 inch (76.2 by 38.1 mm) channel [1/4 inch (6.4 mm) flange by 3/16 inch (4.8 mm) web] weighing 4.1 pounds per foot (6.1 kg per m).

21.5 If the outer shell of the secondary containment tank is in direct contact with the primary containment tank shell, the secondary containment shell may be constructed of steel with a thickness as specified in Table 21.1.

21.6 If the heads of the secondary containment tank are not in direct contact with the heads of the primary tank, the heads of the secondary tank shall have a minimum thickness as stated in Table 13.1 and be braced in accordance with Figures 13.1 and 13.2.

**Table 21.1**  
**Minimum steel thickness for outer shell of horizontal secondary containment tanks in direct contact with primary containment tank shell**

Revised Table 21.1 effective December 15, 2009

Capacity		Maximum diameter of primary tank, inches (m)		Minimum metal thickness, inch (mm)			
U.S. gallons	(kL)			Carbon steel		Stainless steel	
550 or less	(2.08)	48	(1.22)	0.093	(2.36)	0.071	(1.80)
551 – 1100	(2.14 – 4.16)	64	(1.63)	0.093	(2.36)	0.071	(1.80)
1101 – 9000	(4.17 – 34.07)	76	(1.93)	0.123	(3.12)	0.086	(2.18)
1101 – 35,000	(4.17 – 132.49)	144	(3.66)	0.167	(4.24)	0.115	(2.92)
35,001 – 50,000	(134.29 – 189.27)	144	(3.66)	0.240	(6.10)	0.158	(4.01)
50,001 – 75,000	(189.21 – 283.81)	156	(3.97)	0.240	(6.10)	0.158	(4.01)

21.7 If the exterior steel shell extends more than 12 inches (0.3 m) past the head of the primary tank, the portion of the shell that is not in direct contact with the primary tank shall comply with the material and construction requirements specified in Construction, Section 13.

21.8 The thickness of a secondary head that is in direct contact with the primary head may be reduced to the thickness specified in Table 21.1. Unflanged flatheads shall not be used in this type of construction.

## VERTICAL CYLINDRICAL CONSTRUCTIONS

### 22 General

22.1 In addition to complying with the applicable requirements in Sections 4 – 11 for all tank constructions, secondary containment vertical cylindrical tanks shall also comply with the requirements in Construction, Section 23.

**UL COPYRIGHTED MATERIAL –  
NOT AUTHORIZED FOR FURTHER REPRODUCTION OR  
DISTRIBUTION WITHOUT PERMISSION FROM UL**

No Text on This Page

ABDULREHMAN FAZAL || Purchased On : 1/1/19/2008 11:50:04 PM || Order Number : 081119114 || Document : 1 of 1 || ALL RIGHTS RESERVED

***UL COPYRIGHTED MATERIAL –  
NOT AUTHORIZED FOR FURTHER REPRODUCTION OR  
DISTRIBUTION WITHOUT PERMISSION FROM UL***

## 23 Construction

### 23.1 General

23.1.1 The primary containment tank shell of a secondary containment tank shall be constructed in accordance with Part I – Primary Containment Tanks, Vertical Cylindrical Constructions, Sections 14 and 15.

23.1.2 The outer shell of a secondary containment tank shall comply with the requirements specified for Primary Containment Tanks, Vertical Cylindrical Constructions, Sections 14 and 15.

23.1.3 A secondary containment tank shell that is not in direct contact with the primary tank shall have a means to securely position the primary tank within the secondary containment shell.

23.1.4 If the outer shell of the secondary containment tank is in direct contact with the primary containment tank shell, the secondary containment shell may be constructed of steel with a thickness as specified in Table 23.1.

**Table 23.1**  
**Minimum steel thickness for outer shell of vertical secondary containment tanks in direct contact with primary containment tank shell**

Capacity, U.S. gallons <sup>a</sup>	Carbon steel sheet minimum thickness, inch (mm)	
	Shell	Bottom
1100 or less	0.093 (2.36)	0.093 (2.36)
Over 1100	0.123 <sup>b</sup> (3.12)	0.240 (6.10)

<sup>a</sup> For SI units, 1 U.S. Gallon = 3.78 L.  
<sup>b</sup> For a tank more than 25 feet (7.5 m) high, all parts of the shell located more than 25 feet below the top edge of the shell are not to be less than 0.167 inch (4.24 mm) thick.

### 23.2 Tank bottom (floor)

23.2.1 The floor of the secondary containment shall be separate from and in addition to that of the primary containment shell.

## RECTANGULAR CONSTRUCTIONS

### 24 General

24.1 In addition to complying with the applicable requirements in Sections 4 – 11 for all tank constructions, secondary containment rectangular tanks shall also comply with the requirements in Construction, Section 25, and Performance Tests, Section 26.

### 25 Construction

25.1 The primary containment tank shell of a secondary containment tank shall be constructed in accordance with Part I – Primary Containment Tanks, Rectangular Constructions, Sections 16 and 17.

25.2 The outer shell of a secondary containment tank shall comply with the requirements specified for Part I – Primary Containment Tanks, Rectangular Constructions, Sections 16 and 17.

25.3 The floor of the secondary containment shell shall be separate from and in addition to that of the primary containment shell.

### 26 Performance Test

#### 26.1 Hydrostatic strength test

26.1.1 The secondary containment tank shall be tested to demonstrate that the strength of the assembly and welded joints are in accordance with these requirements.

26.1.2 Neither the primary or secondary containment tanks shall rupture or leak when subjected to the Hydrostatic Strength Test, Section 40.

#### 26.2 Top load test

26.2.1 After being subjected to the Top Load Test, Section 41, the tank shall then be subjected to the Leakage Test, Section 39, and shall not leak.

## PART III – DIKED TANKS

### 27 General

#### 27.1 Details

27.1.1 The requirements in this Section cover open and closed top dike tank constructions.

27.1.2 In addition to complying with the applicable requirements in Sections 4 – 11 for all tank constructions and Part I (primary containment tanks) or II (secondary containment tanks) of this standard, a diked tank shall also comply with the requirements in 27.2.1; Construction, Section 28; and Performance Tests, Section 29.

## 27.2 Dike capacity

27.2.1 The actual dike capacity less the volume displaced by the supports or other internal apparatus except the tank shall be at minimum, 110 percent of the actual capacity of the tank.

## 28 Construction

### 28.1 All diked tanks

28.1.1 The dike walls and floor shall be constructed of steel not thinner than 0.093 inch (2.36 mm) if of carbon steel or 0.071 inch (1.80 mm) if of stainless steel.

28.1.2 Buttresses used to stiffen the side walls shall be at least the thickness of the side wall.

28.1.3 Horizontal cylindrical tanks shall be provided with supports that comply with the requirements of Part IV of this standard. If supports are provided for other tank constructions, they shall comply with the requirements of Part IV of this standard.

28.1.4 The supports shall be constructed so that liquid can flow freely at the lowest level in the dike area and shall not become easily blocked by debris.

28.1.5 The supports, tank, or both shall be mechanically secured to, or integral with, the dike to prevent rotation and uplift of the tank.

### 28.2 Open top dike constructions

28.2.1 Access and egress devices (ladder or stairs) shall be provided for the diked area if the height of the interior dike wall exceeds 6 feet (1.8 m).

### 28.3 Closed top dike constructions

28.3.1 Closed top dike tanks shall be provided with steel covers over the dike area to keep precipitation, debris, or other elements from entering the diked area, while also allowing for inspection.

28.3.2 The dike shall be designed such that it cannot be pressurized, should fittings be capped.

28.3.3 Closed top dike constructions shall be provided with a means for emergency venting in accordance with Venting, Section 8.

28.3.4 Closed top dike constructions with covers intended to lift for emergency venting shall not be provided with a means for securement or provision for locking (if locking interferes with the operation of the emergency vent) and shall be marked in accordance with 48.4.1. Vent openings shall be constructed to direct venting upward away from the tank.

28.3.5 Covers shall be constructed so as to reduce the risk of injury to persons during intended use.



## 29 Performance Tests

### 29.1 General

29.1.1 Open and closed top dike tanks shall be subjected to the following tests.

### 29.2 Buoyancy test

29.2.1 When subjected to the Buoyancy Test, Section 42, there shall be no evidence of structural damage, and the tank shall show no evidence of uplifting from the dike floor.

### 29.3 Hydrostatic load test

29.3.1 When subjected to the Hydrostatic Load Test, Section 43, there shall be no structural damage or deflection of the dike walls exceeding  $L/250$ , where  $L$  is the length of the side wall. In addition, there shall be no leakage as evidenced by visual inspection of the dike.

## PART IV – TANK SUPPORTS

### 30 General

#### 30.1 All constructions

30.1.1 These requirements cover supports integral to or secured to a tank or dike.

30.1.2 Tanks on supports shall be constructed to withstand, at minimum, a static load of two times the weight of the full tank without permanent deformation to the tank or supports, or both.

30.1.3 Supports provided with thruholes for tiedown shall be slotted or open-ended to allow for thermal expansion and contraction.

#### 30.2 Horizontal cylindrical tank constructions

30.2.1 Saddles may be constructed as described in Construction, Section 31. Other saddle constructions or means of support are to be evaluated by conducting structural analysis using calculations<sup>a</sup>, or tested in accordance with Performance Tests, Section 32. Other methods of structural analysis calculations, such as finite element, are not prohibited from being used.

<sup>a</sup>L.P. Zick's paper entitled "Stresses in Large Horizontal Pressure Vessels on Two Saddle Supports" and many published sources based on his paper are useful references for this purpose.

### 30.3 Vertical cylindrical tank constructions

30.3.1 Vertical cylindrical tanks on supports such as skirts or legs are to be evaluated by structural analysis using calculations<sup>b</sup> or tested in accordance with Performance Tests, Section 32.

<sup>b</sup>"The Pressure Vessel Design Handbook" by Henry H. Bednar is a useful reference for this purpose.

### 30.4 Rectangular tank constructions

30.4.1 Rectangular tanks on supports are to be evaluated by structural analysis using calculations or tested in accordance with Performance Tests, Section 32.

## 31 Construction

### 31.1 General

31.1.1 Supports shall be constructed of material as described in Materials, Section 5.

### 31.2 Saddles

31.2.1 The minimum material thickness of saddles constructed in accordance with Figure 31.1 shall be as specified in Table 31.1.

31.2.2 Maximum height of saddles, when measured from the lowest portion of the tank shell, shall be 12 inches (305 mm) unless protected by materials having a fire resistance rating of not less than two hours.

31.2.3 The base plate length shall be at least 90 percent of the tank diameter.

31.2.4 The stiffener thickness shall be a minimum of 3/8 inch (9.5 mm) for tank diameters 6 feet (1.8 m) or less and a minimum of 1/2 inch (12.7 mm) for tank diameters greater than 6 feet.

31.2.5 The saddles shall be positioned a distance of D/4 from the end of the primary tank, where D is the diameter of the tank.

**Figure 31.1**  
**Saddles for horizontal cylindrical tanks**

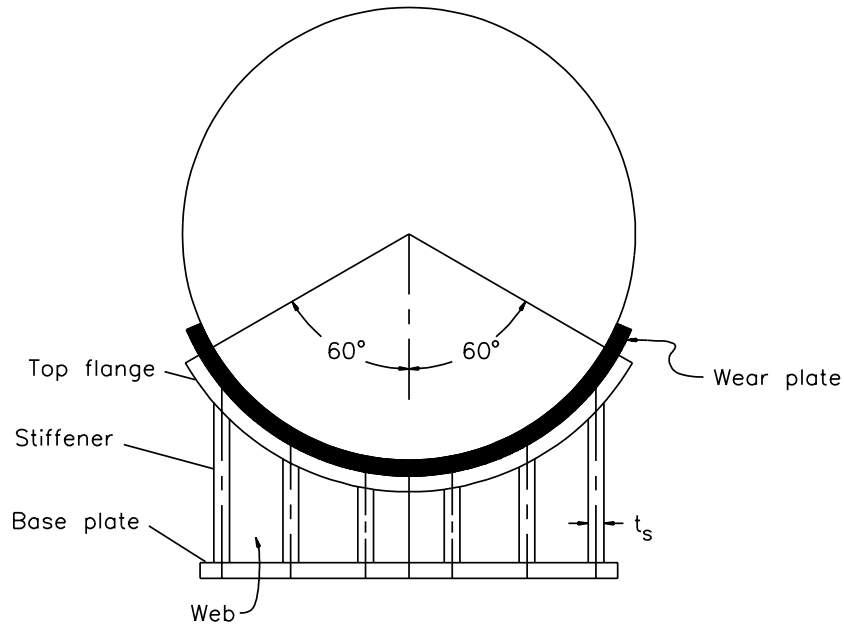

SM519B

**Table 31.1**  
**Minimum material thicknesses for saddle constructions in inches**

Revised Table 31.1 effective December 15, 2009

Part	550 or less	551 – 1100	1101 – 9000	1101 – 35,000	35,001 – 50,000	50,001 – 75,000
Maximum Tank Diameter	48	64	76	144	144	156
Top Flange Thickness	0.093	0.123	0.24	0.560	0.60	1.24
Wear Plate Thickness	0.093	0.123	0.24	0.240	0.365	0.49
Saddle Width	4.5	6.0	6.0	9.0	10	12
Base Plate Thickness	0.123	0.167	0.50	0.75	0.9	1.24
Base Plate Width	6.5	7.5	7.5	10	11	12
Web Thickness	0.093	0.123	0.167	0.240	0.365	0.365
Minimum Number of Stiffeners	3	3	4	6	6	6

31.2.6 Wear plates shall be used for tanks with capacities greater than 550 gallons (2.09 kL), and shall extend a minimum of 0.1 times the radius, in inches, above the saddle tips and have a minimum width of  $b + 10t$  inches, where  $b$  is the width of the saddle and  $t$  is the thickness of the shell. Wear plates for saddles of tanks above 144 inch (3.66 meter) diameter shall be at least 38 inches (965 mm) wide.

Revised 31.2.6 effective December 15, 2009

**UL COPYRIGHTED MATERIAL –  
NOT AUTHORIZED FOR FURTHER REPRODUCTION OR  
DISTRIBUTION WITHOUT PERMISSION FROM UL**

## 32 Performance Tests

32.1 As an option to structural analysis of the support, the tank may be subjected to the Tank Support Load Test, Section 44. There shall be no damage to or permanent deformation of the tank or supports.

## PART V – TANK ACCESSORIES, COMPONENTS, AND SPECIAL CONSTRUCTIONS

### 33 General

#### 33.1 All types

33.1.1 The requirements in this section cover optional tank accessories, components, and special constructions.

#### 33.2 Materials

33.2.1 All materials used in fabrication of the accessory shall be compatible with the base tank, flammable and combustible liquid, and the physical and atmospheric conditions where the device may be used.

33.2.2 Polymerics and elastomers shall be evaluated for compatibility with fluids, surfaces, or atmospheric conditions with which the part comes in contact. These materials shall comply with the requirements for Gaskets and Seals, UL 157.

33.2.3 All accessories shall be constructed to minimize the stresses on the base tank.

### 34 Ladders

34.1 Exterior ladders shall comply with the construction requirements in accordance with the current edition of Occupational Safety and Health Standards, Title 29 of the Code of Federal Regulations, Part 1910, Subpart D, Section 1910.27 – Fixed Ladders.

34.2 Interior ladders shall comply with the exterior ladder requirements except that the climbing surface must be vertical and directly in line with the edge of the tank manhole. Manholes shall not be less than 24 inches (0.6 m) in diameter. Hatch covers, if used, shall not be of the self-locking type if they can be opened only from the outside of the tank.

34.3 Ladders shall be designed to withstand, at minimum, a static load of 1000 pounds (454 kg) for ladders with a climb of 10 feet (3 m) or less and 2000 pounds (909 kg) for ladders with a climb of greater than 10 feet. Suitability shall be determined by test as described in 34.4 and 34.5 or by calculations.

34.4 All ladders shall withstand the load described in 34.5 without damage to or permanent deformation of the ladder or tank.

34.5 Static Load (Ladders) – Ladders with a length of climb of 10 feet (3 m) or less shall support a static load of 1000 pounds (454 kg). The load is to be applied for 1 minute to a 3-1/2 inch (89 mm) wide block resting on the center of the longest rung. Ladders with a length of climb of greater than 10 feet shall support a static load of 2000 pounds (909 kg). The load is to be applied for 1 minute to the center of two rungs spaced 10 feet apart using 3-1/2 inch wide blocks.

**UL COPYRIGHTED MATERIAL –  
NOT AUTHORIZED FOR FURTHER REPRODUCTION OR  
DISTRIBUTION WITHOUT PERMISSION FROM UL**

### 35 Stairs

35.1 Stairs shall comply with the construction and performance requirements in accordance with the current edition of Occupational Safety and Health Standards, Title 29 of the Code of Federal Regulations, Part 1910, Subpart D, Section 1910.24 – Fixed Industrial Stairs.

35.2 Guardrails shall comply with Sub-paragraph 1910-23(d)(1) of the Occupational Safety and Health Standards, Title 29 of the Code of Federal Regulations.

35.3 Spiral stairs on vertical tanks shall additionally comply with Sub-paragraph 1910.23(d)(2) of the Occupational Safety and Health Standards, Title 29 of the Code of Federal Regulations.

35.4 All stairs and guardrails shall withstand the loads described in 35.5 and 35.6, respectively, without damage to or permanent deformation of the ladder or tank.

35.5 Static Load (Stairs) – A static load of 1000 pounds (454 kg) is to be evenly distributed over a one square foot (0.09 m<sup>2</sup>) area on the center of the longest step for a period of one minute.

35.6 Static Load (Guardrail) – A static load of 200 pounds (91 kg) is to be applied in various directions at a point on top of the rail located midway between the supports for a period of one minute. The load is to be applied using a 3-1/2 by 3-1/2 inch (89 by 89 mm) steel plate.

### 36 Runways

36.1 Runways (catwalks) shall comply with the construction requirements in accordance with the Occupational Safety and Health Standards, Title 29 of the Code of Federal Regulations, Part 1910, Subpart D, Section 1910.23 – Guarding Floor and Wall Openings and Holes, sub-paragraph (c) – Protection of open-sided floors, platforms, and runways. Runways used below the top level of the tank are only required to have a guardrail on one side.

36.2 All runways and guardrails shall withstand the loads described in 36.3 and 35.6, respectively, without damage to or permanent deformation of the base ladder or tank.

36.3 Static Load (Runways) – A static load of 1000 pounds (454 kg) is to be evenly distributed over a one square foot (0.09 m<sup>2</sup>) area on the center of the longest step for a period of one minute.

### 37 Heating Coils and Hot Wells

37.1 A heating coil or hot well that is provided as part of a tank assembly and handles a fluid other than that stored in the tank, such as steam or hot water, shall have no joints in that portion located within the tank unless such joints are continuously welded or brazed. The coil or hot well connection shall exit from the tank above the liquid level, unless made of steel having a wall thickness not less than specified for that portion of the tank shell through which the connection exists. A continuous full fillet weld shall be made where a connection pierces the tank or a manhole cover.

### 38 Sumps

38.1 A sump that is provided as part of a tank assembly shall be of steel having a thickness not less than that of the tank shell or bottom. It shall be attached to the tank using a continuous full fillet weld, inside and outside, or the equivalent.

## PERFORMANCE TEST METHODS

### 39 Tank Leakage Test

#### 39.1 Caution

39.1.1 Caution – Testing with air pressure presents a risk of injury to persons and personnel should be instructed in precautions to be taken during such testing. The precautions should include the use of a pressure-relief device that will reduce the risk of the tank becoming pressurized in excess of the specified test pressure.

#### 39.2 Primary containment tanks

39.2.1 The leakage test is to be conducted before painting the tank by a method described in items (a) – (b). There shall be no evidence of leakage or sign of permanent deformation following the leakage test. If subjected to a leakage test pressure, the tank wall, head, or roof may deflect but shall return to its original position and shape when the test pressure is released.

a) Apply internal air pressure and use soap-suds, or equivalent material for the detection of leaks. For a horizontal or rectangular tank, the test gauge pressure is to be not less than 3 psi (21 kPa) or more than 5 psi (35 kPa). For a vertical tank, the test gauge pressure is not to be less than 1-1/2 psi (10 kPa) nor more than 2-1/2 psi (17 kPa) or that gauge pressure above 1-1/2 psi which first causes visible deformation of the tank; or

b) Completely fill the tank with water, applying the pressure specified in item (a) hydrostatically, and examine the tank for leakage.

39.2.1 effective June 28, 2007

39.2.2 Each compartment of a tank having two or more compartments is to be tested separately for leakage.

**UL COPYRIGHTED MATERIAL –  
NOT AUTHORIZED FOR FURTHER REPRODUCTION OR  
DISTRIBUTION WITHOUT PERMISSION FROM UL**

### 39.3 Secondary containment tanks

39.3.1 After completion of the primary containment shell, the tank is to be checked for leakage using the method described in 39.2.1 and 39.2.2 for primary containment tanks.

39.3.2 Upon completion of the finished secondary containment tank, the primary tank is again to be pressurized using the method described in 39.2.1 and 39.2.2 and held for 1 hour to check for leakage. A continuous drop in pressure will be considered evidence of leakage.

39.3.3 While maintaining pressure on the primary tank, the interstitial (annular) space bounded by the primary and secondary tank is to be pressurized to the pressures indicated in 39.2.1 and checked for external leakage by applying a leak detection solution. There shall be no evidence of leakage or sign of permanent deformation following the leakage test. A tank wall, head, or roof may deflect when subjected to the leakage test pressure, but shall return to its original position and shape when the test pressure is released.

39.3.4 As an option to the leakage test described in 39.3.2 and 39.3.3, the annular space may be tested by applying a vacuum of at least 13 inches of mercury for a minimum of 12 hours. If the tank is unable to maintain the vacuum (plus or minus 2 inches of mercury) for the specified time, the tank shall be retested using the method described in 39.3.2 and 39.3.3.

## 40 Hydrostatic Strength Test

### 40.1 General

40.1.1 The hydrostatic strength test is to be conducted as described in 40.3.1 and 40.4.1 using the test apparatus described in 40.2.1. Neither the primary containment tank nor the secondary containment shell shall rupture or leak when subjected to this test.

### 40.2 Test apparatus

40.2.1 The source of water pressure is to be capable of maintaining a gauge pressure of at least 30 psi (207 kPa) for a period of not less than 2 minutes. The pressure gauges are to be calibrated and have a dial range gauge pressure of 0 – 50 or 0 – 60 psi (345 or 415 kPa), a face size of at least 3-1/2 inches (89 mm) in diameter, graduations of a gauge pressure of 1 psi or 10 kPa maximum, and an accuracy of  $\pm 1$  percent of the full scale reading. Piping and fittings as shown in Figure 40.1 are to be appropriate for the test pressure.

### 40.3 Primary containment tanks

40.3.1 The tank and connections are to be arranged as shown in Figure 40.1. All unused openings in the tank to be tested are to be plugged.

- a) The tank is to be completely filled with water, and all air expelled from the tank.
- b) Pressure is to be applied gradually to the tank in increments of a gauge pressure of 5 psi (35 kPa) at a rate not exceeding a gauge pressure of 2 psi (14 kPa) per minute. The gauge pressure is to be held for 2 minutes after each increment of a gauge pressure of 5 psi until the test gauge pressure of 25 psi (172 kPa) is attained.

*Exception: Test gauge pressure of 15 psi (103 kPa) may be used instead of 25 psi if tanks are marked as specified in 48.5.1.*

- c) Once the test pressure is attained, the tank is to be examined for visible signs of leakage or rupture.

### 40.4 Secondary containment tanks

40.4.1 Upon completion of the test on the primary containment shell as described in 40.3.1, pressure is to be reduced in the primary containment shell, the interstitial (annular) space is to be filled with water, and the test method is to be repeated to test the secondary containment shell. Pressure in the primary tank is to be maintained the same as the pressure of the annular space while testing the annular space.



Figure 40.1  
Test apparatus and arrangement

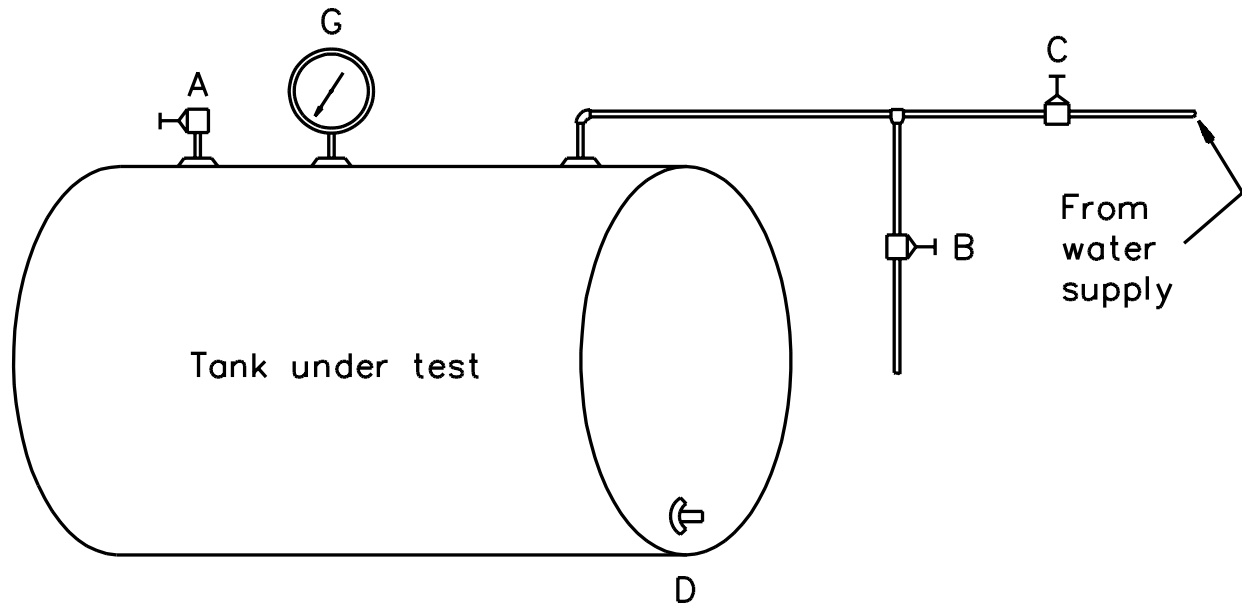

S2788C

- A – Valve for expelling air from tank.
- B – Bleeder valve – should be about same size as C.
- C – Control valve.
- G – A gauge pressure of 0 – 50 psi (0 – 345 kPa).
- D – Drain.

**UL COPYRIGHTED MATERIAL –  
NOT AUTHORIZED FOR FURTHER REPRODUCTION OR  
DISTRIBUTION WITHOUT PERMISSION FROM UL**

#### 41 Top Load Test

41.1 The top surface of flat top tanks is to be subjected to a 1000 pound (454 kg) load, applied over a one square foot (0.09 m<sup>2</sup>) area at the weakest part of the tank top for a period of 5 minutes.

41.2 The load is then to be removed. There shall be no permanent deformation or leakage when subjecting the tank to the Tank Leakage Test, Section, 39.

#### 42 Buoyancy Test

42.1 The diked area is to be filled with water to its maximum capacity while the tank remains empty. This condition is to be maintained for a minimum of one hour. The tank shall not show uplifting from the dike floor.

42.2 The dike is then to be emptied and the tank and dike are then examined. There shall be no evidence of structural damage.

#### 43 Hydrostatic Load Test

43.1 This test is to be conducted immediately following the buoyancy test. The dike is to be emptied and the reference position of the dike determined. The dike shall then be filled with water and examined for structural damage or deflection. There shall be no structural damage or deflection of the dike walls exceeding L/100, where L is the length of the side wall. After the dike is emptied, there shall be no structural damage or permanent deflection of the dike walls. In addition, there shall be no leakage as evidenced by visual inspection of the dike.

43.2 The dike is then to be emptied. There shall be no permanent deformation or leakage when subjecting the tank to the Tank Leakage Test, Section 39.

#### 44 Tank Support Load Test

44.1 A tank provided with integral supports shall show no evidence of permanent deformation or damage to the tank or supports when tested as described in 44.2.

44.2 The tank is to be completely filled with water. An evenly distributed load equal to the weight of the filled tank is to be placed across the top of the filled tank on a line parallel to the longitudinal axis of the tank. The tank and supports shall withstand this load for 2 minutes.

#### 44A Lift Lug Test

Added 44A effective December 15, 2009

44A.1 Fittings intended to be used to lift and move a tank shall be subjected for not less than 1 minute to a load equal to twice the weight of the empty tank. Single or multiple fittings may be tested to establish a load rating for each fitting. A fitting or fittings shall be tested in a manner which simulates the worst case lifting configuration for which each fitting's load rating will be determined.

Added 44A.1 effective December 15, 2009

44A.2 Following this test, the tank shall not leak when tested per the production leakage test. The lift fittings and the tank shall not show evidence of damage, as defined by cracking or tearing of the lift fitting itself, of the tank wall itself, or of any metal weld attachment.

Added 44A.2 effective December 15, 2009

44A.3 As an alternative to testing, calculations at two times the empty tank weight may be used provided that the fitting stresses do not exceed the material's properties and that there is no permanent tank deformation in excess of 1 percent of its original dimensions.

Added 44A.3 effective December 15, 2009

No Text on This Page

ABDULREHMAN FAZAL || Purchased On : 1/1/19/2008 11:50:04 PM || Order Number : 081119114 || Document : 1 of 1 || ALL RIGHTS RESERVED

***UL COPYRIGHTED MATERIAL –  
NOT AUTHORIZED FOR FURTHER REPRODUCTION OR  
DISTRIBUTION WITHOUT PERMISSION FROM UL***

## MANUFACTURING AND PRODUCTION TESTS

### 45 Primary and Secondary Containment Tanks

45.1 Each primary and secondary containment tank, before painting, shall be tested by the manufacturer and determined to be tight against leakage using the method of the Tank Leakage Test, Section 39.

45.2 If leaks are noted during testing, the tank is to be made tight by welding and retested. Defects in welds are to be repaired by chipping or melting out from one or both sides of the joint, as required, and rewelding.

### 46 Diked Tanks

46.1 Each primary or secondary containment tank, before painting, shall be tested by the manufacturer and determined to be tight against leakage using the method of the Tank Leakage Test, Section 39.

46.2 Each dike shell is to be inspected before painting for welding defects with a dye penetrant, magnet-flux, or other acceptable non-destructive testing method. If all seams are double welded (inside and outside), visual inspection may be used. The Hydrostatic Load Test, Section 43, may also be used to determine welding defects.

46.3 If leaks are noted during testing, the tank is to be made tight by welding and retested. Defects in welds are to be repaired by chipping or melting out from one or both sides of the joint, as required, and rewelding.

## MARKINGS

### 47 General

47.1 Each tank shall be marked as indicated in Marking Elements, Section 48, using the method described in Marking Method and Location, Section 49.

### 48 Marking Elements

#### 48.1 All tanks

48.1.1 Each tank shall be marked with:

- a) The manufacturer's name, trade name, or trademark or other descriptive marking which identifies the organization responsible for the product.
- b) One of the following statements, as applicable:
  - 1) "This Tank Requires Emergency Relief Venting. Capacity Not Less Than \_\_\_\_ CFH based on installation within one foot of the tank top," with the appropriate value derived from Table 8.1 inserted; or
  - 2) For tanks provided with a manhole of the long bolt type in accordance with the requirements in 8.10, the manhole cover shall be marked: "This Manhole Is Provided With Long Bolts To Permit Emergency Relief Venting. Do Not Replace With Shorter Bolts."
- c) The statement: "This Tank is Intended for Stationary Installation Only."

UL COPYRIGHTED MATERIAL –  
NOT AUTHORIZED FOR FURTHER REPRODUCTION OR  
DISTRIBUTION WITHOUT PERMISSION FROM UL

- d) If a manufacturer produces tanks at more than one factory, each tank shall have a distinctive marking by which it can be identified as the product of a particular factory.
- e) Identification of the emergency vent openings.
- f) When the tank has integral welded steel supports the tank shall be marked: "On Supports." The mark shall be adjacent to the conformity mark.

48.1.1 effective June 28, 2007

## 48.2 Compartment tanks

48.2.1 In addition to the markings required in 48.1.1, compartment tanks shall also be marked with the following:

- a) The applicable venting statements as described in 48.1.1(b) for each compartment.
- b) Identification of the emergency vent openings for each compartment.

## 48.3 Secondary containment tanks

48.3.1 In addition to the markings required in 48.1.1 and 48.2.1, as applicable, secondary containment tanks shall also be marked with the following statements:

- a) "The Annular Space Requires Emergency Relief Venting. Capacity Not Less Than \_\_\_\_ Cubic Feet Per Hour," with the appropriate value derived from Table 8.1 inserted.
- b) "Pressurize Primary Tank When Pressure Testing Annular Space" or equivalent wording.

## 48.4 Diked tanks

48.4.1 In addition to the markings required by 48.1.1 and 48.2.1, diked tanks shall also be marked with the statements:

- a) "Open Top Diked" or "Closed Top Diked". The mark shall be adjacent to the conformity mark.
- b) The capacity of the diked area in U.S. gallons. The capacity may also be expressed in terms of percent containment of the primary tank.
- c) (For closed top diked tanks only where the cover is used for emergency venting) "Cover Used For Emergency Venting. Do Not Secure Cover."

## 48.5 Rectangular tanks

48.5.1 If a tank is subjected to a gauge pressure 15 psi (103 kPa) hydrostatic test pressure as covered in the Exception to 40.3.1(b), the tank shall be marked to indicate a maximum leakage test gauge pressure of 3 psi (21 kPa).

## 49 Marking Method and Location

49.1 The required marking shall be embossed, etched, stamped on a nameplate of corrosion resistant metal, or as described in 49.2. The markings shall be in a size and style of type corresponding to 18 point Franklin Gothic [1/4 inch (6.4 mm) high letters] or the equivalent. The nameplate shall be attached by welding or brazing or by attaching it by drive screws, rivets, welding, or brazing to a bracket or holder that is then welded or brazed to the tank.

49.2 If a pressure-sensitive label, ink or paint stenciling, or other method is used, it shall comply with the requirements in the Standard for Marking and Labeling Systems, UL 969; be suitable for outdoor use and exposure to fuels and gasoline; and have a minimum surface temperature rating of 60°C (140°F).

49.3 For primary and secondary containment tanks, the nameplate shall be secured to the tank.

49.4 For tanks provided with a manhole of the long bolt type, the marking in 48.1.1 shall be secured directly to the manhole cover.

49.5 For diked tanks, the nameplate shall be secured to the exterior of the dike shell.

No Text on This Page

ABDULREHMAN FAZAL || Purchased On : 1/1/19/2008 11:50:04 PM || Order Number : 081119114 || Document : 1 of 1 || ALL RIGHTS RESERVED

***UL COPYRIGHTED MATERIAL –  
NOT AUTHORIZED FOR FURTHER REPRODUCTION OR  
DISTRIBUTION WITHOUT PERMISSION FROM UL***



## APPENDIX A

## Capacity and Wetted Area Tables

**Table A1**  
Gallon capacity per foot of length

Diameter in inches	U.S. gallons 1-foot length	Diameter in inches	U.S. gallons 1-foot length	Diameter in inches	U.S. gallons 1-foot length
24	23.50	65	172.38	105	449.82
25	25.50	66	177.72	106	458.30
26	27.58	67	183.15	107	467.70
27	29.74	68	188.66	108	475.89
28	31.99	69	194.25	109	485.00
29	34.31	70	199.92	110	493.70
30	36.72	71	205.67	111	502.70
31	39.21	72	211.51	112	511.90
32	41.78	73	217.42	113	521.40
33	44.43	74	223.42	114	530.24
34	47.16	75	229.50	115	540.00
35	49.98	76	235.66	116	549.50
36	52.88	77	241.90	117	558.51
37	55.86	78	248.23	118	568.00
38	58.92	79	254.63	119	577.80
39	62.06	80	261.12	120	587.52
40	65.28	81	267.69	121	597.70
41	68.58	82	274.34	122	607.27
42	71.97	83	281.07	123	617.26
43	75.44	84	287.88	124	627.00
44	78.99	85	294.78	125	638.20
45	82.62	86	301.76	126	647.74
46	86.33	87	308.81	127	658.60
47	90.13	88	315.95	128	668.47
48	94.00	89	323.18	129	678.95
49	97.96	90	330.48	130	690.30
50	102.00	91	337.86	131	700.17
51	106.12	92	345.33	132	710.90
52	110.32	93	352.88	133	721.71
53	114.61	94	360.51	134	732.60
54	118.97	95	368.22	135	743.58
55	123.42	96	376.01	136	754.64
56	127.95	97	383.89	137	765.78
57	132.56	98	391.84	138	776.99
58	137.25	99	399.88	139	788.30
59	142.02	100	408.00	140	799.68
60	146.88	101	416.00	141	811.14
61	151.82	102	424.48	142	822.69
62	156.83	103	433.10	143	834.32
63	161.93	104	441.80	144	846.03
64	167.12				

**Table A2**  
**Wetted areas for horizontal tanks**  
**(Wetted area equals 75 percent of total area)**

Revised Table A2 effective December 15, 2009

Tank length, feet <sup>a</sup>	Tank Diameter, feet <sup>a</sup>											
	3	4	5	6	7	8	9	10	11	12	13	
	Wetted area of tanks with flat heads, square feet <sup>b</sup>											
3	32											
4	39	55										
5	46	65	88									
6	53	74	100	128								
7	60	84	112	142	173							
8	67	93	124	156	190	226						
9	74	102	136	170	206	245	286					
10	81	112	147	184	223	264	308	353				
11	88	121	159	198	239	283	329	377	428			
12	95	131	171	213	256	301	350	400	454	509		
13	102	140	183	227	272	320	371	424	480	537	598	
14	109	150	194	241	289	339	393	447	506	565	628	
15	116	159	206	255	305	358	414	471	532	594	659	
16	123	169	218	269	322	377	435	495	558	622	690	
17	130	178	230	283	338	395	456	518	584	650	720	
18	137	188	242	298	355	414	477	542	610	678	751	
19		197	253	312	371	433	499	565	636	707	781	
20		206	265	326	388	452	520	589	662	735	812	
21		216	277	340	404	471	541	612	688	763	843	
22		225	289	354	421	490	562	636	714	792	873	
23		235	300	368	437	508	584	659	740	820	904	
24		244	312	383	454	527	605	683	765	848	935	
25			324	397	470	546	626	706	791	876	965	
26			336	411	487	565	647	730	817	905	996	
27			347	425	503	584	668	754	843	933	1027	
28			359	440	520	603	690	777	869	961	1057	
29			371	454	536	622	711	801	895	989	1088	
30			383	468	553	641	732	824	921	1018	1118	
31			395	482	569	659	753	848	947	1046	1149	
32				496	586	678	775	871	972	1074	1180	
33				510	602	697	796	895	999	1103	1210	
34				524	619	715	817	918	1025	1131	1241	
35				539	635	734	838	942	1051	1159	1272	
36				553	652	753	860	966	1077	1187	1302	
37				567	668	772	881	989	1103	1216	1333	
38					685	791	902	1013	1129	1244	1363	
39					701	810	923	1036	1155	1272	1394	
40					718	828	944	1060	1181	1301	1425	
41					734	847	966	1083	1207	1329	1455	
42					751	866	987	1107	1233	1357	1486	
43					767	885	1008	1130	1259	1385	1517	

ABDULREHMAN FAZAL || Purchased On : 1/1/19/2008 11:50:04 PM || Order Number : 081119114 || Document : 1 of 1 || ALL RIGHTS RESERVED

**UL COPYRIGHTED MATERIAL –  
 NOT AUTHORIZED FOR FURTHER REPRODUCTION OR  
 DISTRIBUTION WITHOUT PERMISSION FROM UL**

Table A2 Continued on Next Page

Table A2 Continued

Tank length, feet <sup>a</sup>	Tank Diameter, feet <sup>a</sup>										
	3	4	5	6	7	8	9	10	11	12	13
	Wetted area of tanks with flat heads, square feet <sup>b</sup>										
44						904	1029	1154	1284	1414	1547
45						923	1051	1178	1310	1442	1578
46						941	1072	1201	1336	1470	1609
47						960	1093	1225	1362	1798	1639
48						979	1114	1248	1388	1527	1670
49						998	1135	1272	1414	1555	1700
50							1157	1295	1440	1583	1731
51							1178	1319	1466	1612	1762
52							1199	1342	1492	1640	1792
53							1220	1366	1518	1668	1823
54							1246	1389	1544	1697	1854
55							1263	1413	1570	1725	1884
56								1437	1593	1753	1915
57								1460	1622	1781	1945
58								1484	1648	1809	1976
59								1507	1674	1839	2007
60								1531	1700	1867	2037
61									1726	1895	2068
62									1752	1923	2099
63									1778	1951	2129
64									1803	1980	2160
65									1829	2007	2190
66									1855	2036	2221
67										2064	2252
68										2093	2282
69										2121	2313
70										2149	2343
71										2177	2374
72										2205	2405

<sup>a</sup> For SI units, 1 ft = 0.3 m.  
<sup>b</sup> For SI units, 1 ft<sup>2</sup> = 0.09 m<sup>2</sup>.

ABDULREHMAN FAZAL || Purchased On : 1/1/19/2008 11:50:04 PM || Order Number : 081119114 || Document : 1 of 1 || ALL RIGHTS RESERVED

**Table A3**  
**Wetted areas for vertical tanks**  
**(Area of shell to elevation not more than 30 feet above bottom)**

Revised Table A3 effective December 15, 2009

Tank length, feet <sup>a</sup>	Tank Diameter, feet <sup>a</sup>											
	3	4	5	6	7	8	9	10	11	12	13	14
	Wetted area of tanks with flat heads, square feet <sup>b</sup>											
3	28											
4	38	50										
5	47	63	79									
6	56	76	94	113								
7	66	88	110	132	154							
8	75	101	127	151	176	201						
9	85	113	141	170	198	226	255					
10	94	126	157	189	220	251	283	314				
11	103	139	173	208	242	276	311	345	381			
12	113	151	188	227	264	301	340	377	415	452		
13		164	204	246	286	326	368	408	450	490	531	
14		176	220	265	308	351	396	440	484	528	572	616
15		189	236	284	330	377	424	471	519	566	613	660
16		202	251	302	352	402	453	502	554	603	654	704
17			267	321	374	427	481	534	588	641	695	748
18			283	340	396	452	510	565	623	679	735	792
19			298	359	418	477	538	597	657	716	776	836
20			314	378	440	502	566	628	692	754	817	880
21				397	462	527	594	659	727	792	858	924
22				416	484	552	623	691	761	829	899	968
23				435	506	577	651	722	796	867	940	1012
24				454	528	602	679	757	830	905	981	1056
25					550	628	708	785	865	943	1021	1100
26					572	653	736	816	900	980	1062	1144
27					594	678	764	848	934	1018	1103	1188
28					616	703	792	879	969	1056	1144	1232
29						728	821	911	1003	1093	1185	1275
30						753	849	942	1038	1131	1226	1319

<sup>a</sup> For SI units, 1 ft = 0.3 m.  
<sup>b</sup> For SI units, 1 ft<sup>2</sup> = 0.09 m<sup>2</sup>.

**Superseded requirements for  
the Standard for  
Steel Aboveground Tanks for Flammable and Combustible Liquids**

**UL 142, Ninth Edition**

The requirements shown are the current requirements that have been superseded by requirements in revisions issued for this Standard. To retain the current requirements, do not discard the following requirements until the future effective dates are reached.

8.1 Each primary containment tank and each compartment of a compartment tank shall have provision for both normal and emergency venting. The interstitial (annular) space of a secondary containment tank shall have provision for emergency venting. A vent opening shall be in addition to the fill, withdrawal, and liquid level gauge openings.

8.1 effective until December 15, 2009

9.1 Except as noted in 9.3, a manhole for attachment to the top of a tank shall be as illustrated in Figure 9.1. A manhole attached to the shell at a location below the top of the tank or to the head of a tank shall comply with Figure 9.2.

9.1 effective until December 15, 2009

9.2 Except as noted in 9.3, a manhole for attachment to the roof of a vertical cylindrical tank shall be as illustrated in Figures 9.1, 9.2, or 9.3. The reinforcing plate and handles illustrated in Figure 9.3 are optional. A manhole attached to the shell of a vertical tank shall be as shown in Figure 9.2 or 9.4. A manhole of the type illustrated in Figure 9.2 shall comply with Table 9.3 with regard to the minimum thickness of cover plate and bolting flange, and, if larger than 24 inches (0.6 mm) in size, shall also comply with Table 9.4 with regard to diameter of cover plate and bolt circle and the size and number of bolts.

9.2 effective until December 15, 2009

9.4 A manhole-cover joint shall be provided with a ring or face gasket of material determined to be acceptable for use with flammable liquids and having a thickness of not less than 1/8 inch (3.2 mm).

9.4 effective until December 15, 2009

**Figure 6.3**  
**Bottom joints for vertical cylindrical tanks**

Figure 6.3 effective until December 15, 2009

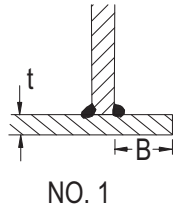

NO. 1  
Double-welded full fillet joint; minimum overlap, "B" - 1/2 inch (12.7 mm) or 1-1/2 t, whichever is greater.

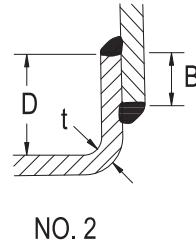

NO. 2  
Double-welded full fillet lap joint; minimum overlap, "B" - 1/2 inch (12.7 mm) or 1-1/2t, whichever is greater; "D" is 5 t or greater, but not less than 1 inch (25.4 mm).

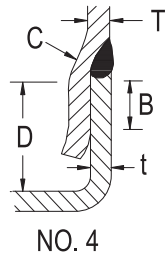
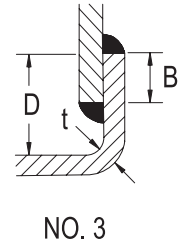

NO. 4  
Groove weld at least equivalent in thickness to that of thinner member joined; minimum overlap, "B" - 1/2 inch (12.7 mm) or 1-1/2 t, whichever is greater; depth of offset, "C" - equals T; "D" is 5t or greater, but not less than 1/2 inch (12.7 mm).

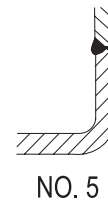

NO. 5  
Double-welded U, V, bevel, or square groove butt joint; full penetration and complete fusion.

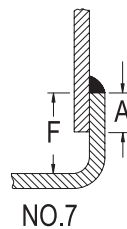
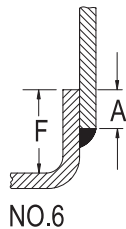

NO. 6  
Single-welded full fillet lap joint, single-welded full fillet lap joint on outside with 1-inch (25.4 mm) intermittent weld spaced not over 12 inches (0.3 m) on inside; minimum overlap, "A" - 1/2 inch (12.7 mm); "F" is five times head thickness or greater, but not less than 1/2 inch (12.7 mm).

S2063g

### Figure 7.1 Pipe connections

Figure 7.1 effective until December 15, 2009

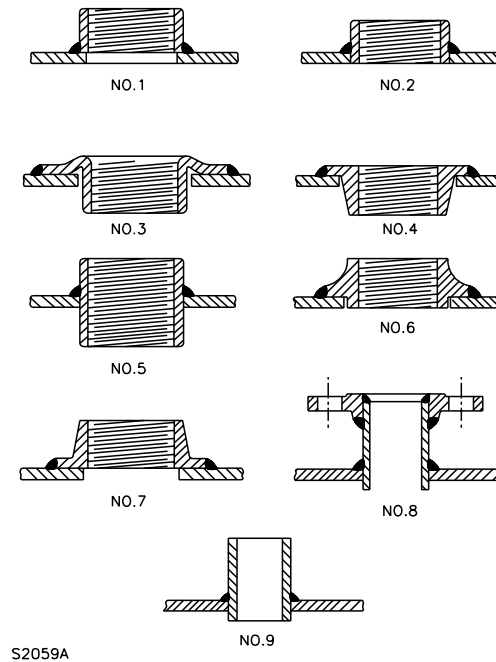

- No. 1 – Half pipe coupling.
- No. 2 – Half pipe coupling.
- No. 3 – Pressed steel, hub inside tank only.
- No. 4 – Forged steel, hub inside tank.
- No. 5 – Full pipe coupling.
- No. 6 – Forged steel, with pilot.
- No. 7 – Forged steel, without pilot.
- No. 8 – Standard pipe nipple and welding flange.
- No. 9 – Standard pipe nipple – may be unthreaded.

#### NOTES –

- 1 All welds are to be full fillet welds, at least 1/8-inch (3.2-mm).
- 2 Pipe connections Nos. 8 and 9 may be trimmed flush.
- 3 Pipe connections Nos. 3, 4, 5, 8, and 9 may be seal welded on the opposite side of the weld shown.

**UL COPYRIGHTED MATERIAL –  
NOT AUTHORIZED FOR FURTHER REPRODUCTION OR  
DISTRIBUTION WITHOUT PERMISSION FROM UL**

**Figure 7.2**  
**Top or shell connections (See Table 7.1)**

Figure 7.2 effective until December 15, 2009

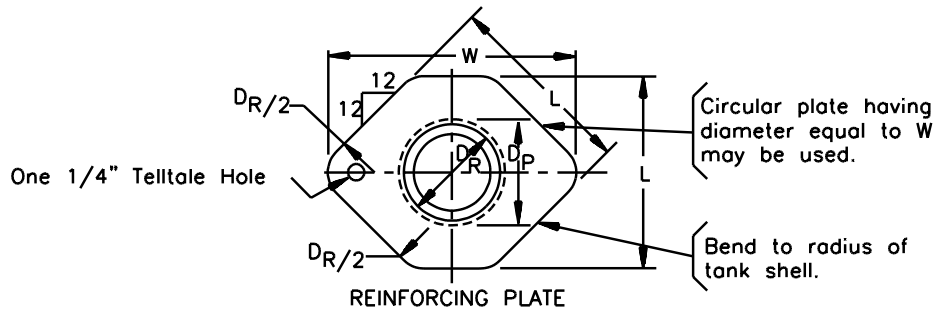
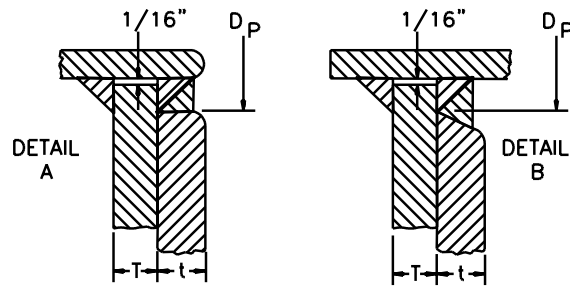
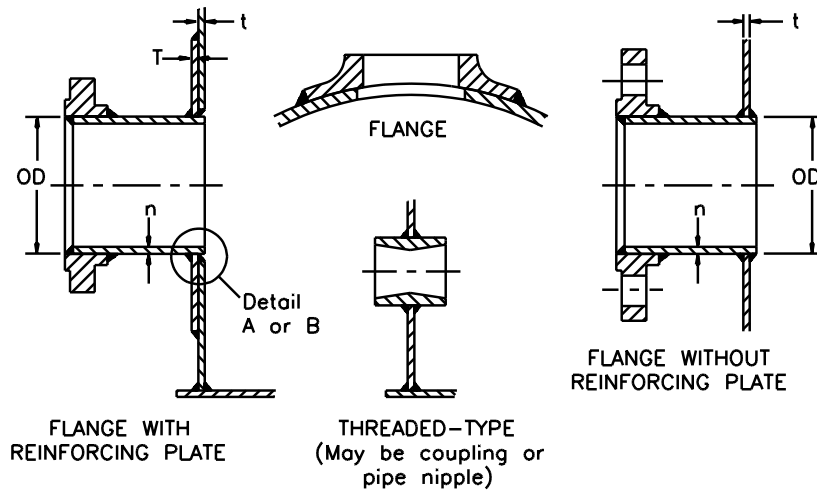

S20600

NOTES -

- 1 All welds are to be full fillet welds, at least 1/8-inch (3.2 mm) radius.
- 2  $D_p$  is the outside diameter of the pipe plus 5/8 inch (0.63 mm).
- 3 For SI units, 1 inch = 25.4 mm.

**UL COPYRIGHTED MATERIAL -  
NOT AUTHORIZED FOR FURTHER REPRODUCTION OR  
DISTRIBUTION WITHOUT PERMISSION FROM UL**



**Figure 9.1**  
**Top manholes (See Table 9.1)**

Figure 9.1 effective until December 15, 2009

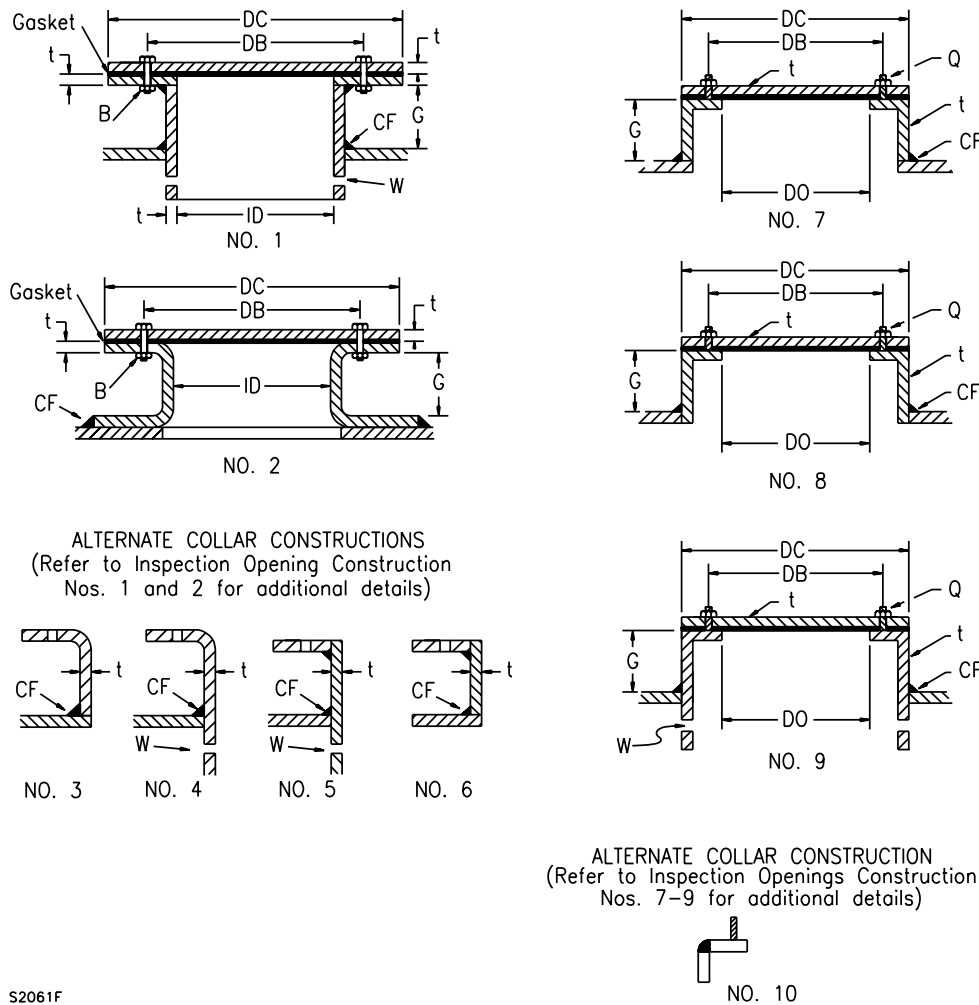

t – Not less than 0.167 inch (4.24 mm) thick.

B – Minimum 1/2-inch (12.7-mm) bolts in 9/16-inch (14.3-mm) holes.

CF – Continuous full fillet weld, at least 1/8 inch (3.2 mm).

G – Minimum 2t.

Q – Minimum 1/2 inch (12.7 mm) threaded studs spaced per Table 9.1.

W – Optional weep holes. Two provided. Minimum 1/4 inch (6.4 mm) diameter through hole, adjacent to the tank shell at the highest point of the tank.

NOTE – Nos. 4 and 5 may be trimmed flush as shown in No. 8.

**UL COPYRIGHTED MATERIAL –  
NOT AUTHORIZED FOR FURTHER REPRODUCTION OR  
DISTRIBUTION WITHOUT PERMISSION FROM UL**

**Figure 9.2**  
**Shell or head manholes (Horizontal Tanks – See Table 9.1; Vertical Tanks – See Table 9.3)**

Figure 9.2 effective until December 15, 2009

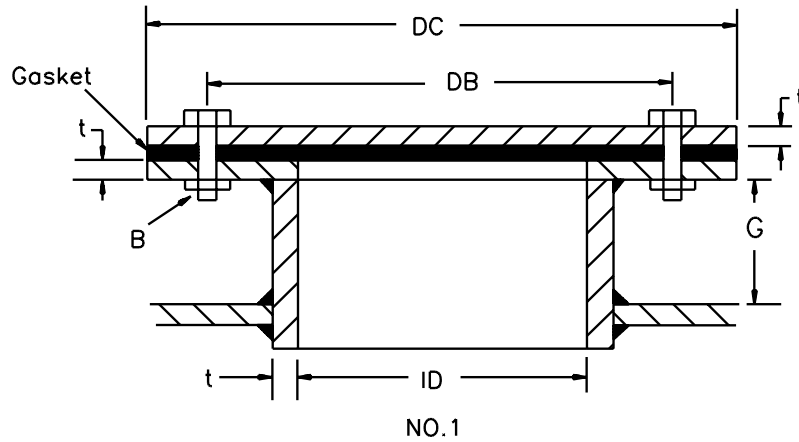

ALTERNATE DESIGNS

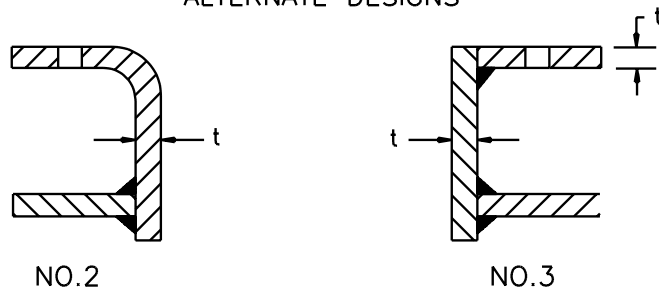

S2062C

t – Not less than 0.167 inch (4.24 mm) thick.

B – Minimum 1/2-inch (12.7-mm) bolts in 9/16-inch (14.3-mm) holes.

G – Minimum 2 inches (50.8 mm) for tanks 6 feet (1828.8 mm) in diameter or larger.

NOTE – All welds are to be full fillet welds, at least 1/8 inch (3.2 mm) radius.

**UL COPYRIGHTED MATERIAL –  
 NOT AUTHORIZED FOR FURTHER REPRODUCTION OR  
 DISTRIBUTION WITHOUT PERMISSION FROM UL**

**Figure 9.3**  
**Roof manholes for vertical tanks (See Table 9.2)**

Figure 9.3 effective until December 15, 2009

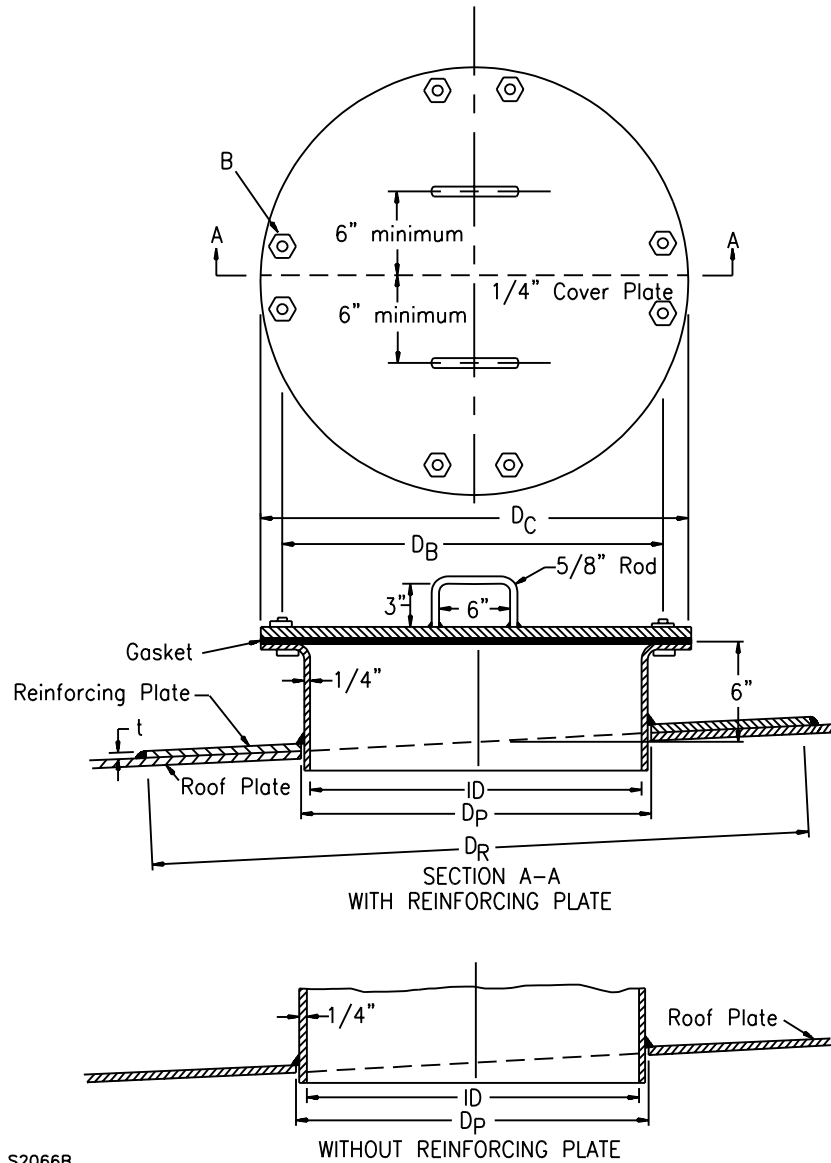

S2066B

t = 1/4 inch

NOTES –

- 1 The manhole construction may be trimmed flush.
- 2 All welds are to be full fillet welds, at least 1/8-inch (3.2-mm) radius.
- 3 For SI units, 1 inch = 25.4 mm.

**Figure 9.4**  
**Shell manholes for vertical tanks (See Tables 9.3 and 9.4)**

Figure 9.4 effective until December 15, 2009

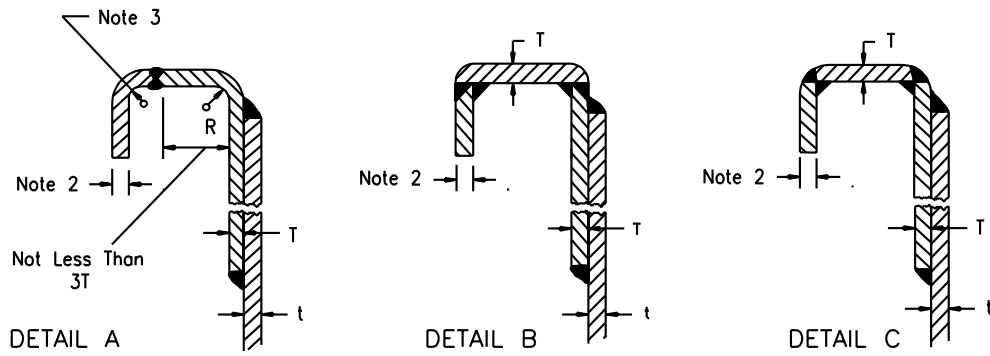
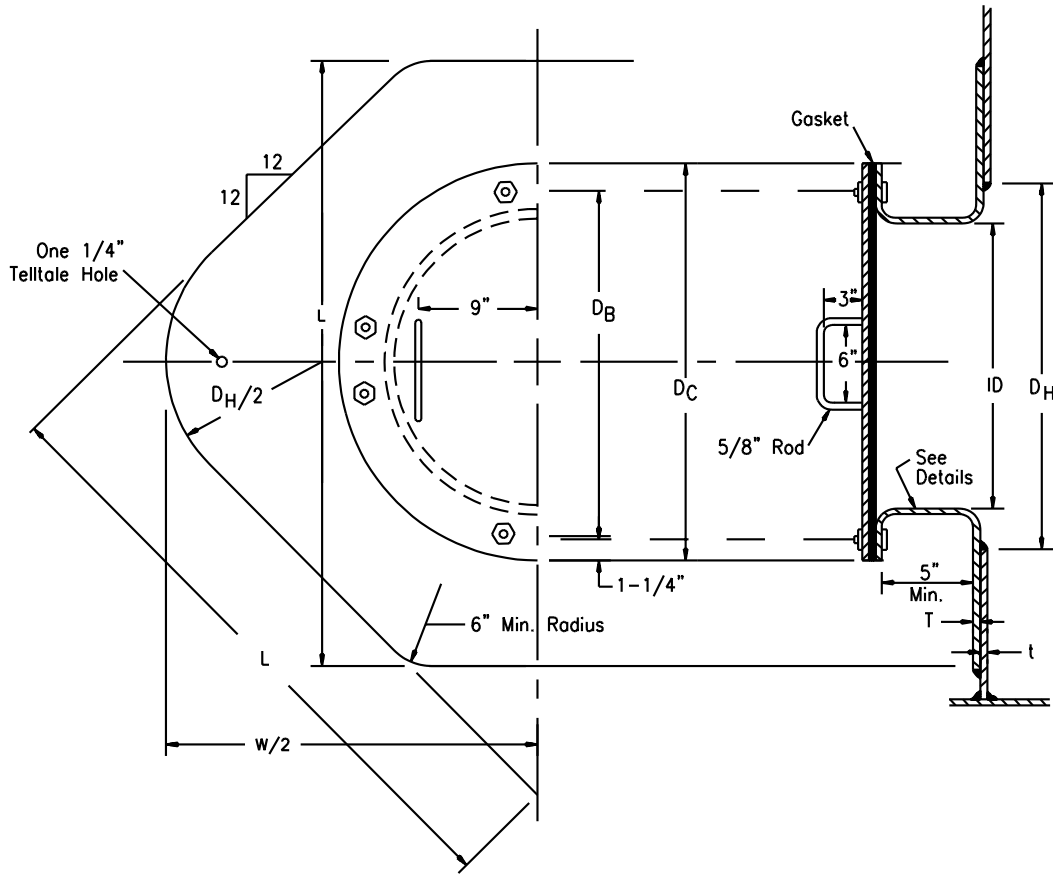

S2067B

NOTES -

1 All welds are to be full fillet welds, at least 1/8-inch (3.2-mm) radius.

2 For SI units, 1 inch = 25.4 mm.

**UL COPYRIGHTED MATERIAL -  
 NOT AUTHORIZED FOR FURTHER REPRODUCTION OR  
 DISTRIBUTION WITHOUT PERMISSION FROM UL**

**Table 13.1**  
**Minimum steel thickness – horizontal tanks**

Table 13.1 effective until December 15, 2009

Actual capacity, U.S. gallons (kL)		Maximum diameter, inches (m)	Minimum steel thickness, inch (mm)	
			Carbon steel	Stainless steel
550 or less	(2.08)	48 (1.22)	0.093 (2.36)	0.071 (1.80)
551 – 1100	(2.14 – 4.16)	64 (1.63)	0.123 (3.12)	0.086 (2.18)
1101 – 9000	(4.17 – 34.07)	76 (1.93)	0.167 (4.24)	0.115 (2.92)
1101 – 35,000	(4.17 – 132.49)	144 (3.66)	0.240 (6.10)	0.158 (4.01)
35,001 – 50,000	(132.50 – 189.27)	144 (3.66)	0.365 (9.27)	0.240 (6.10)

13.1.2 The overall length of a horizontal tank shall not be greater than six times its diameter.

13.1.2 effective until December 15, 2009

13.3.1 A head of a horizontal tank shall be constructed of not more than three pieces for tank diameters of 48 to 96 inches (1.2 to 2.4 m); and four pieces for diameters of 97 to 144 inches (2.42 to 3.6 m). When two or more pieces are used, joints shall be one of the shell joint constructions described in Figure 6.1, except joint No. 6 shall not be used.

13.3.1 effective until December 15, 2009

**Figure 13.1**  
**Bracing for flanged flat heads and bulkheads (See Table 13.2)**

Figure 13.1 effective until December 15, 2009

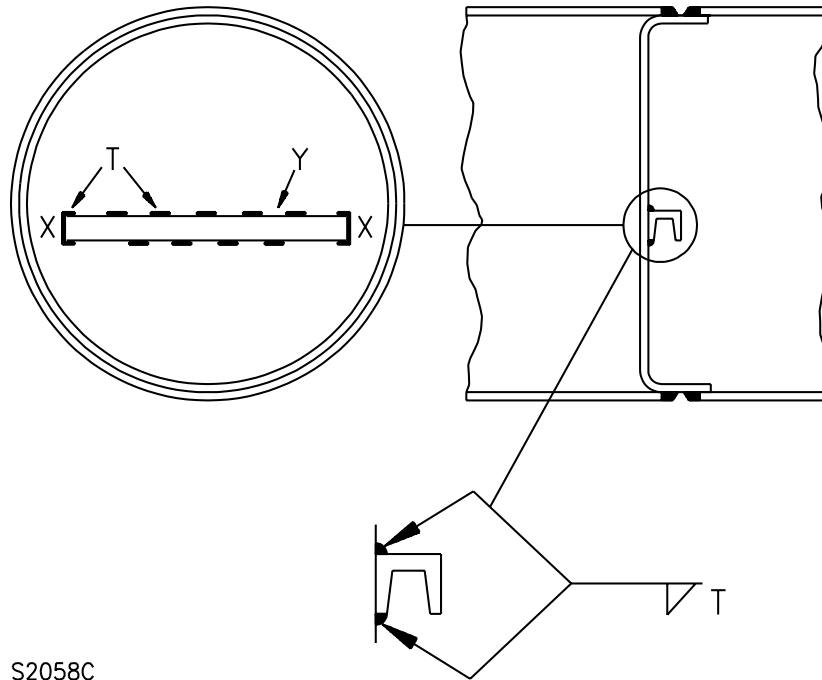

S2058C

T – Tack welds, not over 12 inches (0.3 m) apart.

X – Not over 4 inches (102 mm) from shell.

Y – Bracing [locate 6 inches (152 mm) below center of head].

NOTE – Bracing shall be horizontal as shown or vertical (not as shown).

**UL COPYRIGHTED MATERIAL –  
 NOT AUTHORIZED FOR FURTHER REPRODUCTION OR  
 DISTRIBUTION WITHOUT PERMISSION FROM UL**

**Table 13.3**  
**Dished heads – depth of dish**

Table 13.3 effective until December 15, 2009

Diameter		Minimum depth		Diameter		Minimum depth	
Inches	m	Inches	mm	Inches	m	Inches	mm
Up to 60	(Up to 1.52)	1-1/2	(38)	97 – 108	(2.46 – 2.74)	4-1/2	(114)
61 – 72	(1.55 – 1.83)	2	(51)	109 – 120	(2.77 – 3.05)	5-1/2	(140)
73 – 84	(1.85 – 2.13)	2-1/2	(64)	121 – 132	(3.07 – 3.35)	7	(178)
85 – 96	(2.16 – 2.44)	3-1/2	(89)	133 – 144	(3.38 – 3.66)	8	(203)

13.4.1 A bulkhead of a compartment tank shall be constructed so that leakage through any bulkhead joints will not be directed from one compartment to another. See Figure 13.2 for acceptable bulkhead constructions.

13.4.1 effective until December 15, 2009

13.4.2 A bulkhead of a single or double bulkhead tank, illustrated by Detail 1 of Figure 13.2, shall be constructed of one piece for tank diameters under 72 inches, of not more than two pieces for tank diameters from 72 to 96 inches, and three pieces for diameters of from 97 to 144 inches (2.42 to 3.6 m). When two or more pieces are used, joints shall be in accordance with Figure 6.1 Joints No. 1 or No. 2.

13.4.2 effective until December 15, 2009

**Figure 13.2**  
**Bulkheads for compartment tanks**

Figure 13.2 effective until December 15, 2009

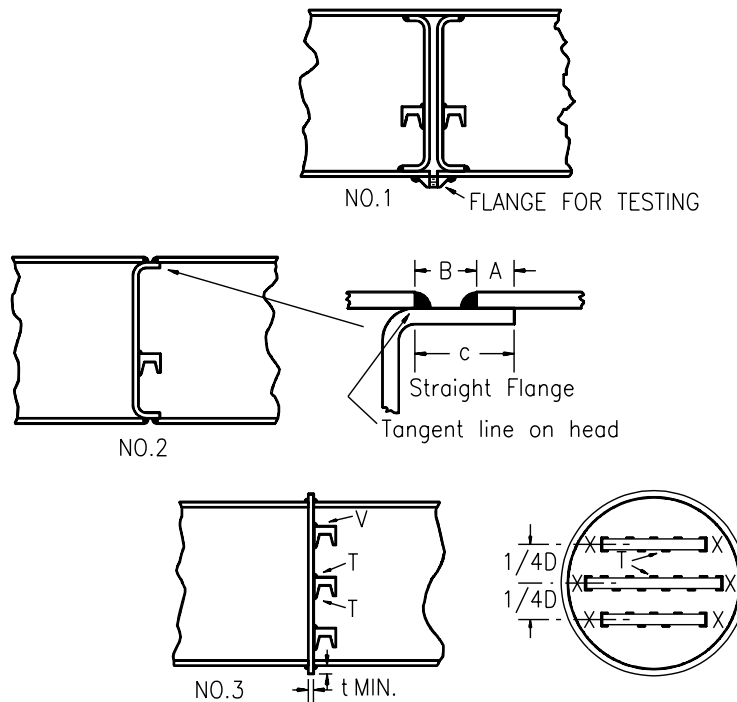

S2056B

A – 1/2 inch (12.7 mm) minimum

B – 3/4 inch (19.1 mm) minimum

C – 1-1/4 inch (31.8 mm) minimum

T – Tack welds, not over 12 inches (0.3 m) apart.

V – Horizontal bracing.

X – Not over 4 inches (102 mm) from shell

**NOTES –**

1 See Figure 13.1 and Table 13.2 for bracing of flanged flat bulkheads (Nos. 1 and 2) and Table 13.4 for bracing of unflanged flat bulkheads (No. 3).

2 For No. 1, the testing flange may be located on the top of the tank.

3 Bracing shall be horizontal as shown or vertical (not as shown).

4 For Nos. 1 and 2, bracing shall be no more than 6 inches (0.15 m) off center.

**UL COPYRIGHTED MATERIAL –  
NOT AUTHORIZED FOR FURTHER REPRODUCTION OR  
DISTRIBUTION WITHOUT PERMISSION FROM UL**



13.4.4 An unflanged flat bulkhead of a compartment tank shall be braced in accordance with Figure 13.2 and Table 13.4.

13.4.4 effective until December 15, 2009

15.1.2 The shell height of a vertical tank shall not be more than 35 feet (10.5 m).

15.1.2 effective until December 15, 2009

15.1.3 The capacity of a vertical tank shall not exceed 50,000 gallons (189 kL).

15.1.3 effective until December 15, 2009

21.3 A secondary tank shell that is not in direct contact with the primary tank shall have standoffs positioned as shown in Figure 21.1.

21.3 effective until December 15, 2009

**Table 21.1**  
**Minimum steel thickness for outer shell of horizontal secondary containment tanks in direct contact with primary containment tank shell**

Table 21.1 effective until December 15, 2009

Capacity		Maximum diameter of primary tank, inches (m)	Minimum metal thickness, inch (mm)				
U.S. gallons	(kL)		Carbon steel		Stainless steel		
550 or less	(2.08)	48	(1.22)	0.093	(2.36)	0.071	(1.80)
551 – 1100	(2.14 – 4.16)	64	(1.63)	0.093	(2.36)	0.071	(1.80)
1101 – 9000	(4.17 – 34.07)	76	(1.93)	0.123	(3.12)	0.086	(2.18)
1101 – 35,000	(4.17 – 132.49)	144	(3.66)	0.167	(4.24)	0.115	(2.92)
35,001 – 50,000	(134.29 – 189.27)	144	(3.66)	0.240	(6.10)	0.158	(4.01)

**Table 31.1**  
**Minimum material thicknesses for saddle constructions in inches**

Table 31.1 effective until December 15, 2009

Part	550 or less	551 – 1100	1101 – 9000	1101 – 35,000	35,001 – 50,000
Maximum Tank Diameter	48	64	76	144	144
Top Flange Thickness	0.093	0.123	0.24	0.560	0.60
Wear Plate Thickness	0.093	0.123	0.24	0.240	0.365
Saddle Width	4.5	6.0	6.0	9.0	10
Base Plate Thickness	0.123	0.167	0.50	0.75	0.9
Base Plate Width	6.5	7.5	7.5	10	11
Web Thickness	0.093	0.123	0.167	0.240	0.365
Minimum Number of Stiffeners	3	3	4	6	6

31.2.6 Wear plates shall be used for tanks with capacities greater than 550 gallons (2.09 kL), and shall extend a minimum of 0.1 times the radius, in inches, above the saddle tips and have a minimum width of  $b + 10t$  inches, where  $b$  is the width of the saddle and  $t$  is the thickness of the shell.

31.2.6 effective until December 15, 2009

**UL COPYRIGHTED MATERIAL –  
 NOT AUTHORIZED FOR FURTHER REPRODUCTION OR  
 DISTRIBUTION WITHOUT PERMISSION FROM UL**

ABDULREHMAN FAZAL || Purchased On : 1/1/19/2008 11:50:04 PM || Order Number : 081119114 || Document : 1 of 1 || ALL RIGHTS RESERVED

**Table A2**  
**Wetted areas for horizontal tanks**  
**(Wetted area equals 75 percent of total area)**

Table A2 effective until December 15, 2009

Tank length, feet <sup>a</sup>	Tank Diameter, feet <sup>a</sup>									
	3	4	5	6	7	8	9	10	11	12
	Wetted area of tanks with flat heads, square feet <sup>b</sup>									
3	32									
4	39	55								
5	46	65	88							
6	53	74	100	128						
7	60	84	112	142	173					
8	67	93	124	156	190	226				
9	74	102	136	170	206	245	286			
10	81	112	147	184	223	264	308	353		
11	88	121	159	198	239	283	329	377	428	
12	95	131	171	213	256	301	350	400	454	509
13	102	140	183	227	272	320	371	424	480	537
14	109	150	194	241	289	339	393	447	506	565
15	116	159	206	255	305	358	414	471	532	594
16	123	169	218	269	322	377	435	495	558	622
17	130	178	230	283	338	395	456	518	584	650
18	137	188	242	298	355	414	477	542	610	678
19		197	253	312	371	433	499	565	636	707
20		206	265	326	388	452	520	589	662	735
21		216	277	340	404	471	541	612	688	763
22		225	289	354	421	490	562	636	714	792
23		235	300	368	437	508	584	659	740	820
24		244	312	383	454	527	605	683	765	848
25			324	397	470	546	626	706	791	876
26			336	411	487	565	647	730	817	905
27			347	425	503	584	668	754	843	933
28			359	440	520	603	690	777	869	961
29			371	454	536	621	711	801	895	989
30			383	468	553	640	732	824	921	1018
31			395	482	569	659	753	848	947	1046
32				496	586	678	775	871	972	1074
33				510	602	697	796	895	999	1103
34				524	619	715	817	918	1025	1131
35				539	635	734	838	942	1051	1159
36				553	652	753	860	966	1077	1187
37				567	668	772	881	989	1103	1216
38					685	791	902	1013	1129	1244
39					701	810	923	1036	1155	1272
40					718	828	944	1060	1181	1301
41					734	847	966	1083	1207	1329
42					751	866	987	1107	1233	1357
43					767	885	1008	1130	1259	1385

ABDULREHMAN FAZAL || Purchased On : 1/1/19/2008 11:50:04 PM || Order Number : 081119114 || Document : 1 of 1 || ALL RIGHTS RESERVED

UL COPYRIGHTED MATERIAL –  
 NOT AUTHORIZED FOR FURTHER REPRODUCTION OR  
 DISTRIBUTION WITHOUT PERMISSION FROM UL

Table A2 Continued on Next Page

**Table A2 Continued**

Tank length, feet <sup>a</sup>	Tank Diameter, feet <sup>a</sup>									
	3	4	5	6	7	8	9	10	11	12
	Wetted area of tanks with flat heads, square feet <sup>b</sup>									
44						904	1029	1154	1284	1414
45						923	1051	1178	1310	1442
46						941	1072	1201	1336	1470
47						960	1093	1225	1362	1798
48						979	1114	1248	1388	1527
49						998	1135	1272	1414	1555
50							1157	1295	1440	1583
51							1178	1319	1466	1612
52							1199	1342	1492	1640
53							1220	1366	1518	1668
54							1246	1389	1544	1725
55							1263	1413	1570	1753
56								1437	1593	1781
57								1460	1622	1809
58								1484	1648	1839
59								1507	1674	
60								1531	1700	
61									1726	
62									1752	
63									1778	
64									1803	
65									1829	
66									1855	

<sup>a</sup> For SI units, 1 ft = 0.3 m.  
<sup>b</sup> For SI units, 1 ft<sup>2</sup> = 0.09 m<sup>2</sup>.

**Table A3**  
**Wetted areas for vertical tanks**  
**(Area of shell to elevation not more than 30 feet above bottom)**

Table A3 effective until December 15, 2009

Tank length, feet <sup>a</sup>	Tank Diameter, feet <sup>a</sup>									
	3	4	5	6	7	8	9	10	11	12
	Wetted area of tanks with flat heads, square feet <sup>b</sup>									
3	28									
4	38	50								
5	47	63	79							
6	56	76	94	113						
7	66	88	110	132	154					
8	75	101	127	151	176	201				
9	85	113	141	170	198	226	255			

**UL COPYRIGHTED MATERIAL –**  
**NOT AUTHORIZED FOR FURTHER REPRODUCTION OR**  
**DISTRIBUTION WITHOUT PERMISSION FROM UL**

Table A3 Continued on Next Page

Table A3 Continued

Tank length, feet <sup>a</sup>	Tank Diameter, feet <sup>a</sup>									
	3	4	5	6	7	8	9	10	11	12
	Wetted area of tanks with flat heads, square feet <sup>b</sup>									
10	94	126	157	189	220	251	283	314		
11	103	139	173	208	242	276	311	345	381	
12	113	151	188	227	264	301	340	377	415	452
13		164	204	246	286	326	368	408	450	490
14		176	220	265	308	351	396	440	484	528
15		189	236	284	330	377	424	471	519	566
16		202	251	302	352	402	453	502	554	603
17			267	321	374	427	481	534	588	641
18			283	340	396	452	510	565	623	679
19			298	359	418	477	538	597	657	716
20			314	378	440	502	566	628	692	754
21				397	462	527	594	659	727	792
22				416	484	552	623	691	761	829
23				435	506	577	651	722	796	867
24				454	528	602	679	757	830	905
25					550	628	708	785	865	943
26					572	653	736	816	900	980
27					594	678	764	848	934	1018
28					616	703	792	879	969	1056
29						728	821	911	1003	1093
30						753	849	942	1038	1131

<sup>a</sup> For SI units, 1 ft = 0.3 m.  
<sup>b</sup> For SI units, 1 ft<sup>2</sup> = 0.09 m<sup>2</sup>.